

Architectural
elements

CO
AV
R
O

— A legacy of craftsmanship

1970 marked the birth of a vision. A vision of always innovating, always transforming. Pushing the boundaries of material science. For over fifty years, our passion for innovation has driven us from crafting ornate decor to pioneering technology materials in the industry, to Duropolymer. Always seeking to infuse the enduring with the revolutionary.

With each turn of the calendar, we — at Orac — have transcended our original identity. From our genesis as Orac to our expansion into Orac Decor, our journey now brings us back to where it all began: Orac, coming full circle. We are more than artisans of decor; we are pioneers, visionaries, storytellers of interior.



1970

Start of Ostend Research and Application Company

1980



Focus on decorative ornaments

1992



Introduction of flexible products

2000



Start of extrusion

2002



Second generation management

2010



Solar field and ISO14001 certification

2012



Modern concept

ORAC

We shed our old skin — Orac Decor — to emerge simply as Orac, a name that encapsulates our essence and our expansive vision for the future.

IT —

Il 1970 ha segnato la nascita di una visione. La visione di innovare sempre, di trasformare sempre. Spingersi oltre i confini della scienza dei materiali. Da oltre cinquant'anni, la nostra passione per l'innovazione ci ha spinto a passare dalla creazione di decorazioni ornamentali alla creazione di materiali tecnologici pionieristici nell'industria del Duropolymer. Sempre alla ricerca di fondere ciò che è duraturo con il rivoluzionario. A ogni giro di calendario, noi di Orac, abbiamo superato la nostra identità originaria. Dalla nostra genesi come Orac alla nostra espansione in Orac Decor il nostro viaggio ci riporta ora al punto dove tutto è iniziato: Orac, chiudendo il cerchio. Non siamo solo artigiani dell'arredamento, ma pionieri, visionari e narratori di interni.

PT —

1970 marcou o início de uma visão. Uma visão inovadora e de transformação. Explorando os limites da ciência nos materiais. Há mais de cinquenta anos que a nossa paixão pela inovação nos impulsiona, passamos do fabrico artesanal de ornamentos para a liderança no desenvolvimento de materiais tecnológicos para a indústria, como o Duropolymer. Sempre em busca de aliar o duradouro ao revolucionário. A cada mudança de ano, nós - na Orac - superamos a nossa identidade original. Desde a nossa génese como Orac até à expansão para Orac Decor, a nossa viagem leva-nos agora de volta para onde tudo começou: Orac, o círculo está completo. Somos mais do que os artesãos da decoração; somos os pioneiros, visionários, os contadores de histórias dos interiores.

AR —

شهد عام 1970 ولادة رؤية. رؤية الابتكار الدائم والتحول الدائم. دفع حدود علم المواد. على مدى أكثر من خمسين عامًا، شغفنا بالابتكار قادنا من صناعة الديكورات المزخرفة، إلى المواد التكنولوجية الرائدة في الصناعة، إلى دوروبوليمر. نسعى دائمًا إلى دمج ما هو دائم مع ما هو ثوري. مع كل دورة زمنية، نحن - في أوراك - نتجاوزنا هويتنا الأصلية. من نشأتنا باسم أوراك إلى توسعنا إلى أوراك ديكور. رحلتنا الآن تعيدنا إلى حيث بدأ كل شيء: أوراك، إكمال الدائرة. نحن أكثر من مجرد حرفيين في الديكور؛ نحن رؤاد، وأصحاب رؤية، ورواة في عالم الداخل.

FR —

1970 a marqué la naissance d'une vision. La vision de toujours innover, de toujours transformer. Repousser les limites de la science des matériaux. Depuis plus de cinquante ans, notre passion pour l'innovation nous a conduits de la fabrication d'ornements décoratifs à la création de matériaux technologiques pionniers dans l'industrie jusqu'au Duropolymer. Nous cherchons toujours à marier le révolutionnaire au durable. À chaque tournant du calendrier, nous - chez Orac - avons transcendé notre origine. De notre genèse en tant qu'Orac à notre expansion en tant qu'Orac Decor, notre voyage nous ramène aujourd'hui là où tout a commencé : Orac, la boucle est bouclée. Nous sommes plus que des artisans de la décoration ; nous sommes des pionniers, des visionnaires, des narrateurs dans le monde de l'intérieur.

At Orac, we've always believed that there are many sides to a wall, and we are committed to choosing the good one. In a world where design often feels transient, we've chosen a different path.



Sustainability goes beyond the use of recycled materials; it's about designing ideas that stand the test of time. We understand that true sustainability means creating products that remain relevant for generations, not just a few fleeting years.



— A commitment carved in walls

IT —
Un impegno scolpito nelle pareti. Noi di Orac abbiamo sempre creduto che un muro abbia molta importanza. In un mondo in cui il design sembra spesso passeggero, abbiamo scelto un cammino diverso. La sostenibilità va oltre l'uso di materiali riciclati; si tratta di progettare idee che resistono nel tempo. Siamo consapevoli che la vera sostenibilità significa creare prodotti che rimangano pertinenti per generazioni, non solo per qualche anno.

AR —
التزام محفور على الجدران. في ORAC، نؤمن دائماً بوجود جوانب عديدة للجدار، ونحن ملتزمون باختيار الجانب الجيد. في عالم يبدو فيه التصميم عابراً في معظم الأحيان، اخترنا طريقاً مختلفاً. تتجاوز الاستدامة استخدام المواد المعاد تدويرها؛ ويتعلق الأمر بإبتكار تصاميم تصمد أمام اختبار الزمن. نحن ندرك أن الاستدامة الحقيقية تعني إبتكار منتجات تظل مناسبة لأجيال عديدة، وليس فقط لبضع سنوات عابرة.

PT —
Na Orac, acreditamos que as paredes têm muitas caras, e estamos comprometidos em escolher a melhor. Num mundo em que o design muitas vezes parece efêmero, escolhemos um caminho diferente. A sustentabilidade vai além do uso de materiais reciclados; trata-se de conceber ideias que resistem ao teste do tempo. Acreditamos que a verdadeira sustentabilidade significa criar produtos que se destaquem durante várias gerações e não apenas durante alguns anos.

FR —
Chez Orac, nous pensons qu'un mur peut avoir plusieurs aspects, et nous nous engageons à choisir le meilleur. Dans un monde où le design peut sembler éphémère, nous avons pris une voie différente. Pour nous, la durabilité va au-delà de l'utilisation de matériaux recyclés, c'est trouver des idées de conception qui durent dans le temps. La véritable durabilité signifie créer des produits pertinents pour les générations à venir, et pas seulement pour quelques années.



— Every wall is a blank canvas



Where others see a flat surface, we see a world of possibilities. A clean primer, waiting for a little intervention. A bare base, in need of shape and dimension. A neutral support, asking to be someone's project and the centre of their attention. Which is all why, at Orac, we like to say we're visual artists of sorts — taking walls as a field of experimentation and at any time, seeking to honour their unique creative potential.

IT —

Dove gli altri vedono una superficie piatta, noi vediamo un mondo di possibilità. Una tela perfetta per realizzare piccoli interventi. Una base neutra, a cui dare forma e dimensione. Una parete che vuole essere il progetto di qualcuno e il centro del suo mondo. Ecco perché a noi di Orac piace dire che siamo come degli artisti visivi: consideriamo i muri come aree da sperimentare e cerchiamo di onorare in ogni momento il loro unico potenziale creativo.

PT —

Um quadro em branco, à espera de uma pequena intervenção. Uma base simples, a precisar de ganhar forma e dimensão. Um suporte neutro, à espera do projeto de alguém que o torne o centro das atenções. É por isso que, na Orac, gostamos de dizer que somos uma espécie de artistas visuais - tornando as paredes um campo de experiências a qualquer momento, na procura de explorar e honrar o seu potencial criativo único.

AR —

حيث يرى الآخرون مجرد سطحًا مستويًا، نرى نحن عالمًا من الاحتمالات الإبداعية اللانهائية. طبقة تأسيس نظيفة، تنتظر القليل من التدخل. قاعدة مجردة، بحاجة إلى التشكيل والأبعاد. مساحة فارغة، تطلب أن تكون مشروع شخص ما، ومركز اهتمامه. ولهذا السبب، في ORAC، نود أن نصف أنفسنا كفنانون بصريون من نوع ما - حيث نعتبر الجدران مساحات للتجارب ونسعى في أي وقت إلى إبراز إمكاناتها الإبداعية الفريدة.

FR —

Là où d'autres voient une surface plane, nous voyons un monde de possibilités. Un socle impeccable, qui attend une petite intervention. Une base vierge, qui a besoin d'une forme et d'une dimension. Un support neutre, qui demande à être le projet de quelqu'un et le centre de son attention. C'est pourquoi, chez Orac, nous aimons dire que nous sommes des sortes d'artistes visuels, considérant les murs comme un champ d'expérimentation et cherchant à tout moment à honorer leur potentiel créatif unique.

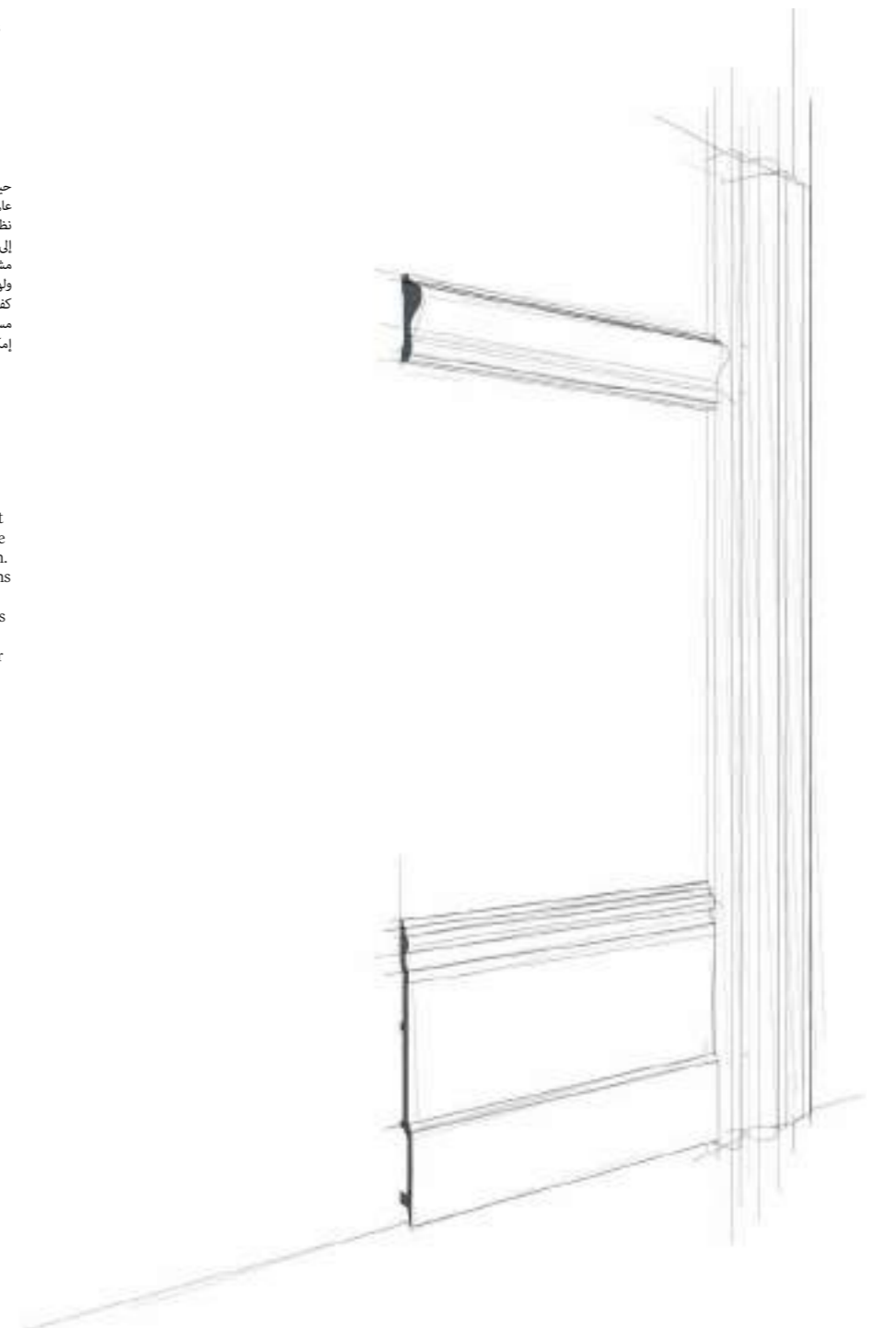



Whether it's a touch of the contemporary or a nod to the classics, each of our products is a chameleon, adept at taking on the character you desire. Here are some glimpses into the myriad of ways our products can animate, define and transform interiors.

Every setting, every angle reveals new potential. A new story to be told.

Unexpected possibilities

IT —

Che si tratti di un tocco contemporaneo o di un rimando al classico, ogni nostro prodotto è camaleontico, abile nell'assumere l'aspetto che desiderate. Ci piace dare un'occhiata alla miriade di modi in cui i nostri prodotti possono adattarsi, definirsi e trasformare gli spazi. Ogni ambiente, ogni angolo può avere un nuovo potenziale. Una nuova storia da raccontare.

PT —

Quer seja com um toque mais contemporâneo ou prestando homenagem aos clássicos, cada um dos nossos produtos adapta-se como um camaleão, capaz de assumir a personalidade que desejar. Gostamos de lhe proporcionar perspectivas diferentes sobre as infinitas possibilidades de dar vida, definir e transformar espaços com os nossos produtos. Cada cenário, cada ângulo revela um novo potencial. Uma nova história a ser contada.

AR —

سواء كانت لمسة من الفن المعاصر أو لمحة إلى الكلاسيكيات، فإن كل منتج من منتجاتنا يتكيف مثل الحرباء؛ يارع في اتخاذ الشخصية التي تلي توقعاتكم. إليكم بعض للمحات عن تعدد الطرق التي يمكن لمنتجاتنا من خلالها إحياء المساحات، تحديدها وتحويلها. يكشف كل مكان وكل زاوية عن إمكانات جديدة. قصة جديدة تستحق أن تروى.

FR —

Qu'il s'agisse d'une touche contemporaine ou d'un clin d'œil aux classiques, chacun de nos produits est un caméléon, capable de prendre le caractère que vous souhaitez. Nous aimons vous donner un aperçu de la myriade de façons dont nos produits peuvent agrémente, définir et transformer les espaces. Chaque décor, chaque angle révèle un nouveau potentiel. Une nouvelle histoire à raconter.

Content

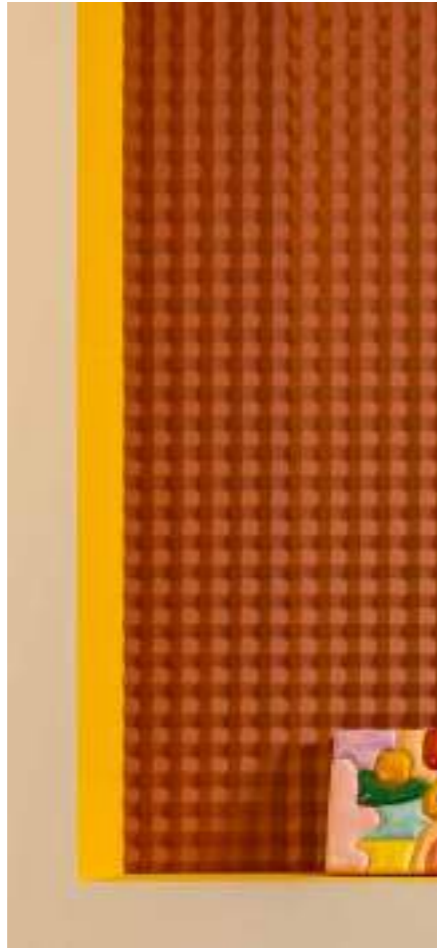

EN –

9	Unexpected possibilities
12	About today
22	Uncut modern
32	Vibrant allure
44	Essential still

57 Products

58	Materials
62	Product Overview
64	— 01 Cornice mouldings
92	— 02 3D Wall covering
108	— 03 Skirting boards
122	— 03 Panel mouldings
134	— 05 Indirect Lightings
148	— 06 Deco elements
158	— 07 The perfect finish
162	— 08 Flexible products

IT –

9	Possibilità inaspettate
12	Da oggi
22	Il semplice moderno
32	Allure vibrante
44	Sempre essenziale

57 Prodotti

58	Materiali
62	Sommario prodotti
64	— 01 Cornici soffitto
92	— 02 Rivestimento murale 3D
108	— 03 Battiscopa
122	— 04 Cornici parete
134	— 05 Illuminazione indiretta
148	— 06 Elementi decorativi
158	— 07 La finitura perfetta
162	— 08 Profili flessibili

PT –

9	Possibilidades inesperadas
12	De hoje
22	Moderno sem cortes
32	Fascínio vibrante
44	Sempre essencial

57 Produtos

58	Materiais
62	Resumo de produto
64	— 01 Sancas
92	— 02 Revestimento de parede 3D
108	— 03 Rodapés
122	— 04 Perfis
134	— 05 Iluminação indireta
148	— 06 Elementos decorativos
158	— 07 O acabamento perfeito
162	— 08 Produtos flexíveis

AR –

9	احتمالات غير متوقعة
12	بشأن اليوم
22	حديث ببساطة
32	مظهر نابض بالحياة
44	دائما ضروري

57 منتجات

58	المواد
62	نظرة عامة على المنتجات
64	01 كرائيش
92	02 تغطية للجدران ثلاثية الأبعاد
108	03 وزرات
122	04 قوالب للجدران
134	05 إضاءة غير مباشرة
148	06 أصناف للزينة
158	07 مظهر نهائي مثالي
162	08 المنتجات المرنة

FR –

9	Des possibilités inattendues
12	À propos d'aujourd'hui
22	Moderne à l'état pur
32	Allure vibrante
44	Essentiel encore

57 Produits

58	Matériaux
62	Aperçu produits
64	— 01 Corniches
92	— 02 Revêtements muraux 3D
108	— 03 Plinthes
122	— 04 Cimaises
134	— 05 Éclairage indirect
148	— 06 Éléments décoratifs
158	— 07 La finition parfaite
162	— 08 Produits flexibles

About today

At times, the modern is inclined to the here and now. Freed from the transience of fashion, it reveals a classic for the future. We are delighted to see it happen. The legacy of an era is revisited to create something new.

IT –

Alcune volte, il moderno segue la tendenza. Liberato dalla temporaneità della moda, rivela un classico per il futuro. Noi ci teniamo che ciò avvenga. L'eredità di un'epoca viene rivisitata per creare qualcosa di nuovo. Un tocco audace in omaggio al presente e al futuro.

AR –

إرث من الحرفية في بعض الأحيان، تميل الحدائثة إلى الوقت الحاضر، بعد أن تحررت من كونها مجرد موضة عابرة، فإنها تكشف عن قطعة كلاسيكية للمستقبل. ونحن سعداء لرؤية ذلك يتحقق. إعادة النظر في إرث من حقبة زمنية سابقة لخلق شين جديد، لمسة جريئة تكرمها للحاضر والغد.

PT –

Por vezes, o moderno é influenciado pela atualidade. Livre da temporariedade da moda, revela-se um clássico para o futuro. Ficamos encantados por ver isso acontecer. O legado de uma época é revisitado para criar algo novo. Um toque de ousadia em homenagem ao presente e ao futuro.

FR –

Parfois, le moderne est tourné vers le présent. Libéré de l'éphémère de la mode, il révèle un classique pour l'avenir. Nous sommes ravis de voir cela se produire. L'héritage d'une époque est revisité pour créer quelque chose de nouveau. Une touche d'audace en hommage au présent et à demain.



1. C990 p.77 2. CX188 p.142 3. PX209 p.131 4. W217 p.99 5. W218 p.99 6. SX182 p.111

IT—
Il bianco incontra i colori primari: un gioco di contrasti originale.

PT—
O branco encontra-se com as cores primárias: uma interação audaz e cheia de contraste.

AR—
يلتقي اللون الأبيض مع الألوان الأساسية: تفاعل جريء وتناقض مثير.

FR—
Le blanc rencontre les couleurs primaires: un jeu audacieux et contrasté.

ORAC

Unexpected possibilities

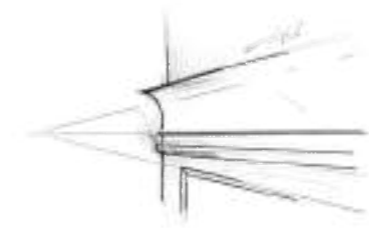

C990 INFINITY + CX188

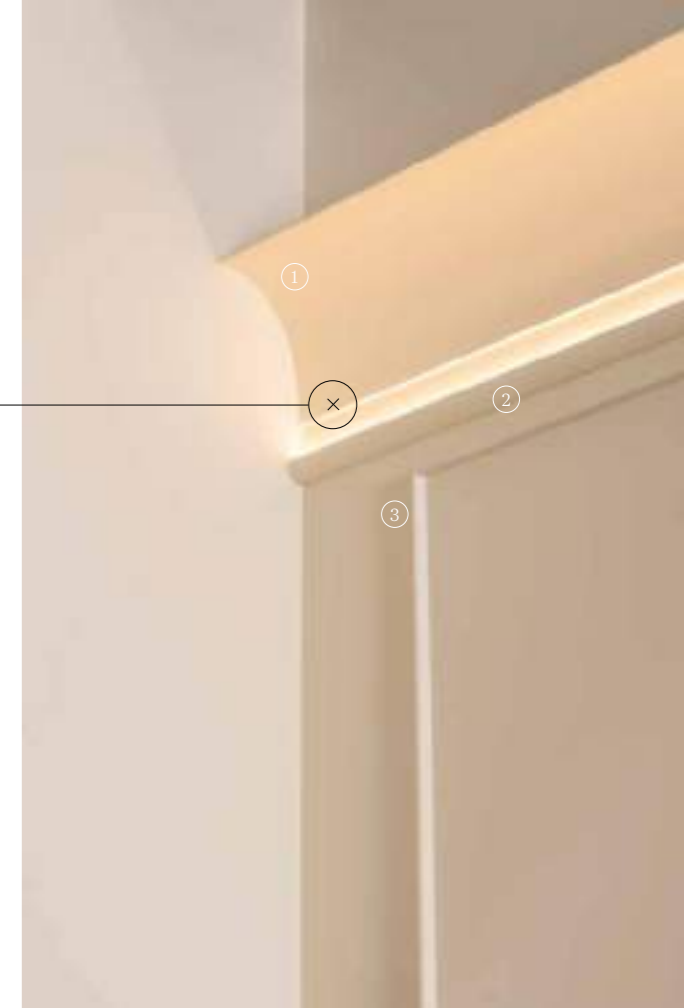

1. C990 p.77 2. CX188 p.142 3. PX209 p.131

3. PX209 p.131



White meets primary colours: a bold, contrasting interplay.

About today

IT —
Grandi forme 3D ritagliano uno spazio dall'estetica audace.

PT —
Grandes formas em 3D criam um espaço esteticamente arrojado.

AR —
الأشكال الثلاثة الأبعاد الكبيرة ترسم مساحة ذات جمال جريء.

FR —
Des formes 3D importantes façonnent un espace au design audacieux.

1. **W115** p.102

Large 3D shapes carve out a boldly aesthetic space.

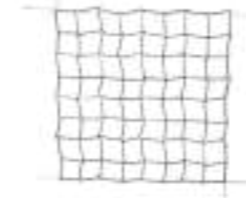

W115 SLOPE



W218 QUILT



2. **W218** p.99 3. **W217** p.99 4. **SX182** p.111



ORAC

Unexpected possibilities

Eclectic blend of rounded 3D panels and vivid colour contrasts.

¹ CX190 | CX190F p.142 ² SX194 | SX194F p.131 ³ W114 | W114F p.98

¹ CX190 | CX190F p.142 ² SX194 | SX194F p.131 ³ W114 | W114F p.98

IT —
Miscela eclettica di pannelli 3D arro-
tondati e contrasti di colori vivaci.

PT —
Uma mistura eclética de painéis
3D arredondados com contrastes
vibrantes.

AR —
مزيج من اللوحات الثلاثية الأبعاد المستديرة والألوان
الزاهية المتباينة.

FR —
Mélange éclectique de panneaux 3D
arrondis et de contrastes de couleurs
vives.



About today

Each room a vibrant canvas with 3D textured walls, daringly immersive. We invite you to dive in and explore.



¹ W110 p.96

¹ W110 p.96



IT —
Ogni stanza è una tela fremente con pareti realizzate in 3D, molto coinvolgenti. Vi invitiamo a vivere questa esperienza a fondo, se lo desiderate.

PT —
Cada divisão é um quadro vibrante de texturas em 3D, imersas em ousadia. Fazemos o convite: Deixe-se envolver.

AR —
تبدو كل غرفة وكأنها لوحة نابضة بالحياة مع جدران ثلاثية الأبعاد ذات جرأة غامرة. نحن ندعوكم للغوص فيها، إن اردتم.

FR —
Chaque pièce est une toile vibrante avec des murs 3D texturés, offrant une immersion audacieuse. Nous vous invitons à plonger dans cet univers, si vous le souhaitez.



Uncut modern

Unexpected possibilities

IT —

Le singolari conquiste dell'età moderna ci toccano sempre. La progressività della mente. Il modo in cui la modestia si fonde con la sottile grandezza. Tracciamo con amore linee pulite, apprezziamo la grazia minimalista e l'audacia ornamentale. Il nostro attaccamento alla modernità ci spinge a prestare attenzione ai dettagli.

AR —

إننا نتأثر دائماً بالإنجازات الفريدة للعصر الحديث. التحرر العقلي الإبداعي. الطريقة التي تمتزج بها البساطة مع الفخامة الخفية. نحن نرسم بولع خطوط نقية، ونقدر الأناقة البسيطة والجرأة الوحشية. إن حبنا للحدائث يحفزنا على الاهتمام بالتفاصيل.

PT —

Somos frequentemente surpreendidos pelas conquistas da era moderna. A evolução do pensamento. A forma como a simplicidade se mistura sutilmente com a grandeza. Gostamos das linhas simples que traçamos, valorizamos a graciosidade minimalista e a audácia do brutalismo. O nosso respeito para com a modernidade leva-nos a estar atentos aos detalhes.

FR —

Nous sommes perpétuellement émus par les réalisations singulières de l'ère moderne. La progressivité de l'esprit. La façon dont la modestie se mêle à la grandeur subtile. Nous traçons avec amour des lignes épurées, nous apprécions la grâce minimaliste et l'audace brute. Notre goût pour la modernité nous incite à soigner les détails.

We are perpetually moved by the singular achievements of the modern age. The progressiveness of the mind. The way modesty blends with subtle grandeur. We lovingly trace clean lines, value minimalist grace and brutalist audacity. Our affection for modernity encourages our attentiveness to detail.

1. P9900 p.126 2. SX194 p.131 3. SX180 p.114



IT —
Linee slanciate, forme angolari ed eleganza minimalista in un'armonia moderna.

PT —
Linhas suaves, contornos pronunciados e a elegância minimalista em harmonia com a modernidade.

AR —
مزيج من الخطوط الأنيقة والأشكال الزاوية والأناقة البسيطة في تناغم عصري.

FR —
Des lignes épurées, des formes anguleuses et une élégance minimaliste dans une harmonie moderne.

Sleek lines, angular shapes and minimalist elegance in modern harmony.

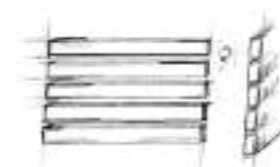

W111 BAR



- 4. C391 p.79
- 5. C393 p.79
- 6. W111 p.101
- 7. W116 p.101
- 8. W119 p.101
- 9. CX190 p.116



ORAC

Unexpected possibilities

Modern Art Deco vibe:
an understated,
layered elegance.

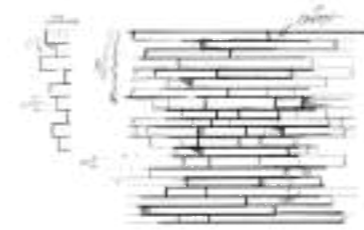

W216 MATRIX

7. C392 p.79 8. C390 p.79 9. P7070 p.126 10. SX180 p.114

- 1. C391 p.79
- 2. C393 p.79
- 3. CX190 p.130
- 4. W216 p.102
- 5. SX207 p.118



P7070

IT —
Vibrazioni Art Deco moderne:
un'eleganza sobria e stratificata.

PT —
A vibração moderna da Art Deco:
uma elegância discreta e em camadas.

AR —
أجواء آرت ديكو حديثة، أناقة متعددة الطبقات.

FR —
L'ambiance Art déco moderne :
une élégance discrète et stratifiée.

Symmetry reimagined:
U-profiles dance on walls and gracefully embrace ceilings.



¹ CX190 p.116

ORAC

Unexpected possibilities

IT —
Simmetria reimmaginata: i profili a U danzano sulle pareti e abbracciano con grazia i soffitti.

PT —
A reivenção da simetria: os perfis em U dançam nas paredes e abraçam graciosamente os tetos.

AR —
إعادة تصور التماثل: قطع على شكل حرف U تراقص على الجدران وتحضن الأسقف بأناقة.

FR —
La symétrie revisitée : les profils en U dansent sur les murs et embrassent gracieusement les plafonds.



² CX190 | CX190F p.116



³ CX190F p.116



¹ SX180 p.114

Stepped lines
translate a modern
Art Deco vision from
floor to ceiling.

¹ SX180 p.114 ² CX188 p.00 ³ C393 p.79 ⁴ C394 p.79 ⁵ C391 p.79



IT —
Le linee a gradini traducono una moderna visione Art Déco dal pavimento al soffitto.

PT —
As linhas em degrau conduzem uma visão moderna da Art Déco do chão até ao teto.

AR —
ترجم الخطوط المتدرجة رؤية 'أرت ديكو' معاصرة من الأرض إلى السقف.

FR —
Les lignes en escalier traduisent une vision art déco moderne du sol au plafond.



⁶ C991 + 2xP9900 p.77 ⁷ CX188 p.142

Vibrant allure

IT —

Ci piace entrare in un mondo di sorprese artistiche, dove l'eleganza classica incontra svolte audaci e coraggiose, creando un'esperienza unica nel suo genere. Un regno dell'inaspettato, dove la raffinatezza incontra l'estro in una celebrazione della creatività.

PT —

Amamos entrar num mundo cheio de surpresas em forma de arte, onde a elegância clássica se encontra com mudanças ousadas e destemidas, criando uma experiência única. Um mundo imprevisível, onde a elegância se mistura com a fantasia para celebrar a criatividade.

AR —

نحن نحب الدخول إلى عالم من المفاجآت الفنية، حيث تجتمع الأناقة الكلاسيكية مع التحولات الجريئة، مما يخلق تجربة فريدة من نوعها. عالم غير متوقع، حيث يلتقي الرقي مع النزوة في احتفال بالابداع.

FR —

Nous aimons explorer un univers d'art surprenant, mêlant l'élégance classique à l'audace pour créer une expérience unique. Un royaume imprévisible, où sophistication et fantaisie se rencontrent pour célébrer la créativité.

We love to step into a world of artful surprises, where classic elegance meets daring, audacious twists, creating a one-of-a-kind experience. A realm of the unexpected, where sophistication meets whimsy in a celebration of creativity.

1. C332 p.74 2. W214 p.96 3. W215 p.96 4. SX138 p.113

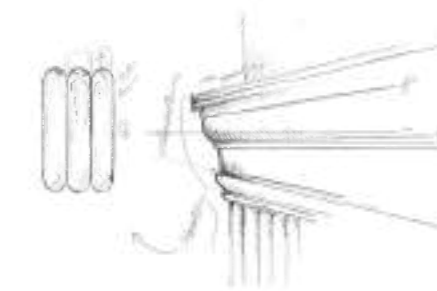

C332 NOBLESSE
W214 HILL BEAD XL

IT —
Una bellissima collisione di consistenze e colori; motivi vibranti e tonalità profonde che creano un'armonia inaspettata.

PT —
Um encontro ousado entre textura e cor; padrões vibrantes e tons profundos que criam uma harmonia surpreendente.

AR —
اصطدام مرح من الملمس واللون؛ أنماط نابضة بالحياة وألوان عميقة تخلق تناغمًا غير متوقع.

FR —
Une collision espiègle de textures et de couleurs ; des motifs vibrants et des teintes profondes créant une harmonie inattendue.

A mischievous collision of texture and colour; vibrant patterns and deep hues crafting an unexpected harmony.



1. C332 p.74 2. W215 p.96 3. SX138 p.113 4. W214 p.96 5. W110 p.96 6. PX209F p.131 7. WX210F p.95 8. WX211F p.95



2. W215 p.96 3. SX138 p.113 4. W214 p.96



Walls oozing with glamour and abundance, beckoning you into their captivating design narrative.

IT — Pareti che trasmettono glamour e abbondanza e che vi invitano a entrare nella loro accattivante narrazione di design.

PT — Paredes que transbordam glamour e abundância, que convidam a entrar nesta cativante narrativa de design.

AR — جدران تتضح بالسحر والوفرة، تدعوكم إلى قصة تصميمها الخلابة.

FR — Des murs qui débordent de glamour et d'abondance et qui vous invitent à entrer dans leur récit captivant.



¹ PX175 p.129 ² P8030 p.124

IT—
Un dipinto di contrasti: dove dettagli ornamentali e tinte serene trovano un'espressione audace.

PT—
Um quadro de contrastes: onde detalhes ornamentados e tons serenos encontram uma expressão ousada.

AR—
لوحة من التباين: حيث تجد التفاصيل الزخرفية والألوان الهادئة تعبيراً جريئاً.

FR—
Un tableau de contrastes où les détails ornementaux et les teintes sereines s'expriment avec audace.

A canvas of contrast:
where ornate details
and serene hues find
daring expression.



¹ PX175 p.129 ² P8030 p.124



³ P3020 p.125 ⁴ P3020A p.133 ⁵ P8050 p.124



1- PX120 p.129 2- P4020 p.124

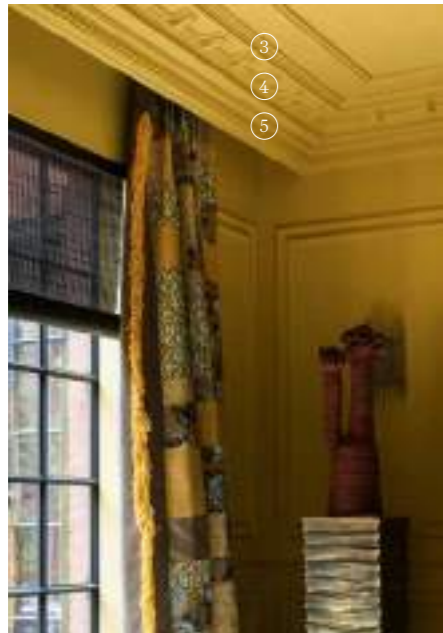

3- C305 p.70 4- C307A p.70 5- C211 p.70

Untamed creativity
blooms in a lavish
fusion of colour and
intricate design.



1- PX120 p.129 2- P4020 p.124 3- C305 p.70 4- C307A p.70 5- C211 p.70 6- DX170-2300 p.154 7- D330LR p.154

IT —
La creatività sboccia in una sontuosa
fusione di colori e motivi intricati.

PT —
Uma criatividade sem regras que se
destaca numa fusão luxuosa de cor e
design.

AR —
يزدهر الإبداع الجامع في مزيج فاخر من الألوان
والأنماط المعقدة.

FR —
La créativité sauvage s'épanouit dans
une somptueuse fusion de couleurs et
de motifs complexes.

Whenever you fancy a change,
our products are ready for
a repaint.



1- PX120 p.129 2- P4020 p.124 3- C305 p.70 4- C307A p.70 5- C211 p.70

IT—
Ogni volta che desideri un cambiamento, i nostri prodotti sono pronti per essere riverniciati.

PT—
Sempre que desejar uma mudança, os nossos produtos estão prontos a ser repintados.

AR—
كلما أردت التغيير، منتجاتنا جاهزة لإعادة الطلاء.

FR—
Quand vous avez envie de changer, nos produits sont prêts à être repeints.



Essential still

ORAC

Unexpected possibilities

We love to embrace the timeless charm of bygone eras as it speaks fluently in the language of today. A demonstration of how classic forms can be reinterpreted to remain ever-relevant.

Essential still

IT —

Ci piace molto quando il fascino senza tempo delle epoche passate parla correntemente nella lingua di oggi. Una dimostrazione di come le forme classiche possano essere reinterpretate per rimanere sempre attuali.

PT —

Adoramos quando o charme intemporal das épocas passadas se expressa fluentemente na linguagem de hoje. Uma demonstração de como as formas clássicas se podem reinventar e se manterem atuais.

AR —

نحب عندما يتحدث السحر الخالد للعصور الماضية بطلاقة بلغة اليوم. عرض لكيفية إعادة استخدام الأشكال الكلاسيكية لتبقى دائماً مناسبة.

FR —

Nous apprécions que le charme intemporel des époques révolues puisse s'exprimer naturellement dans le langage contemporain. Une démonstration de la manière dont les formes classiques peuvent être réinterprétées pour rester toujours pertinentes.

1- C343 p.66 2- P8020 p.124 3- P4020 p.124 4- SX206 p.113



IT —
Elementi raffinati in una sequenza tutt'altro che arbitraria sulle pareti emanano equilibrio e presenza silenziosa.

PT —
Nas paredes, elementos sofisticados numa sequência planeada transmitem equilíbrio e serenidade

AR —
عناصر راقية، مرتبة على الحائط بشكل غير اعتباطي، تضفي التوازن والحضور الهادئ.

FR —
Des éléments raffinés, disposés sur le mur dans un ordre qui n'a rien d'arbitraire, dégagent un équilibre et une présence tranquille.

C343 HERITAGE

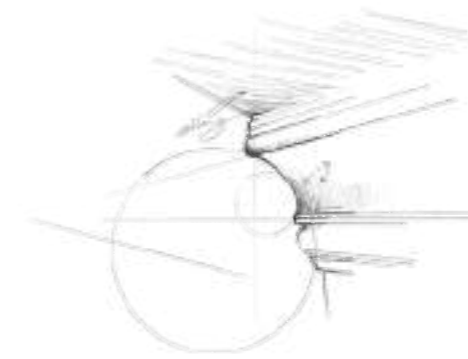

Refined elements,
in a far from arbitrary
sequence on the wall,
exude balance and
discrete presence.





ORAC

Unexpected possibilities

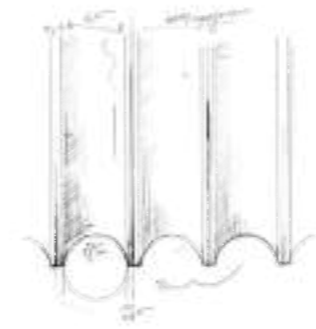

W109 VALLEY

Poised grace in every line,
creating an atmosphere of
calm sophistication.

1. W109 p.98 2. P9010 p.124 3. P9050 p.126



1. W109 p.98 2. P9010 p.124 3. P9050 p.126 4. SX155 p.112

IT —
Una grazia composta in ogni linea,
che crea un'atmosfera di tranquilla
raffinatezza.

PT —
O equilíbrio gracioso de cada linha que
cria uma atmosfera calma e sofisticada

AR —
جمال متوازن في كل خط، يخلق جوًّا من الرقي الهادئ.

FR —
Une grâce suspendue dans chaque
ligne, créant une atmosphère de
calme et de sophistication.

Towering ceilings crowned with grand cornices offer a narrative of timeless opulence.



1. P8050 p.124



3. C305 p.70 4. C307A p.70 5. C211 p.70

2. PX175 p.129 3. C305 p.70 4. C307A p.70 5. C211 p.70 6. P8030 p.124 7. SX191 p.115



IT —
I soffitti svettanti coronati da grandi cornici offrono una sensazione di opulenza senza tempo.

PT —
Os tetos altos coroados por grandes sancas oferecem uma narrativa de opulência intemporal.

AR —
تعطي الأسقف العالية المتوجة بكرانيش كبيرة صورة عن الرخاء الخالد.

FR —
Les hauts plafonds couronnés de grandes corniches offrent une image d'opulence intemporelle.



ORAC

Unexpected possibilities

Grandeur in every detail, framed by a bold monochromatic use of saturated colours.



¹- C343 p.66 ²- P8020 p.124 ³- P4020 p.124 ⁴- SX191 p.115

¹- C343 p.66 ²- P8020 p.124 ³- P4020 p.124 ⁴- SX191 p.115 ⁵- DX170-2300 p.154 ⁶- D330LR p.154

IT —
Grandezza in ogni dettaglio, incorniciata da un coraggioso uso monocromatico di colori saturi.

PT —
Grandeza em cada detalhe, enquadrada por uma utilização monocromática e ousada de cores saturadas.

AR —
عظمة في كل التفاصيل، يُبرزها استخدام أحادي اللون جريء لألوان مشبعة.

FR —
La grandeur dans chaque détail, encadrée par une utilisation monochromatique audacieuse de couleurs saturées.

¹- P8030 p.124 ²- CX160 p.89 ³- C332 p.74



Enhance our products with textured paint for an artisanal finish that adds depth and character to any room.

IT —
Migliora i nostri prodotti con vernice testurizzata per ottenere una finitura artigianale che aggiunga profondità e carattere a qualsiasi stanza

PT —
Eleve os nossos produtos com a aplicação de tinta texturizada para criar um acabamento artesanal que adiciona profundidade e personalidade a qualquer ambiente

AR —
قم بتعزيز منتجاتنا باستخدام الطلاء المزخرف للحصول على لمسة نهائية حرفية تضيف عمقًا وشخصية إلى أي غرفة.

FR —
Rehaussez nos produits avec de la peinture texturée pour une finition artisanale qui ajoute de la profondeur et du caractère à n'importe quelle pièce.



Products

Discover our architectural elements, made for walls. Every product is an innovation with user ease in mind, designed to enhance and transform interiors. We propose a palette that matches styles and meets ideas. So that your walls can become the canvas for your imagination.

IT –

Scoprite i nostri elementi architettonici realizzati per le pareti. Ogni prodotto è un'innovazione che tiene conto della facilità d'uso, progettato per valorizzare e trasformare gli interni. Proponiamo una tavolozza che si abbina agli stili e incontra le idee. In modo che le vostre pareti possano diventare la tela per la vostra immaginazione.

PT –

Descubra os nossos elementos arquitetónicos feitos para as paredes. Cada produto inovador é pensado para ser aplicado facilmente, desenhado para valorizar e transformar interiores. Apresentamos uma seleção de cores que combinam estilos e se adequam às suas ideias.

AR –

اكتشف عناصرنا المعمارية، مصنوعة للجدران. كل منتج هو ابتكار مع مراعاة سهولة الاستخدام، مصممة لتعزيز وتحويل الديكورات الداخلية. نقترح لوحة ألوان تتوافق مع الأنماط وتلبي الأفكار. بحيث يمكن أن تصبح جدرانك لوحة لخيالك.

FR –

Nous vous invitons à découvrir nos éléments architecturaux, faits pour les murs. Chaque produit est une innovation qui vise à faciliter la vie de l'utilisateur, conçu pour améliorer et transformer vos intérieurs. Nous proposons une palette qui s'harmonise avec les styles et répond aux idées. Pour que vos murs deviennent la toile de votre imagination.



Materials

In-house engineered material compositions

MATERIALI INGEGNERIZZATI
MATERIAIS DE ENGENHARIA
مواد مصممة هندسيًا
MATÉRIAUX TECHNIQUES

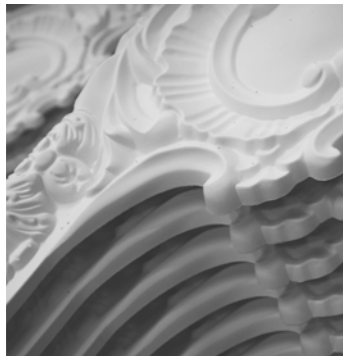

PUROTOUCH®

A high-quality, medium-density polyurethane that allows fine details.

— Poliuretano di alta qualità e media densità che consente dettagli ben definiti
— Um poliuretano de média densidade e de alta qualidade que permite detalhes precisos

Detail Design ☆☆☆

— بوليوريثين عالي الجودة، عالي الكثافة يسمح بالحصول على تفاصيل دقيقة

— Un polyuréthane de qualité à densité moyenne qui permet de créer des détails fins.

Impact Resistance ☆☆☆

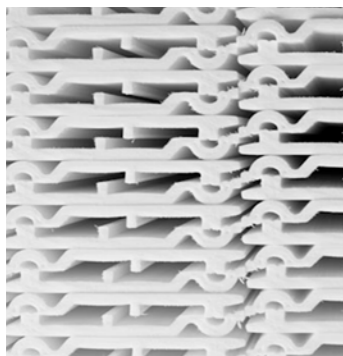

DUROPOLYMER®

An extruded and impact-resistant polymer based on a high-density polystyrene.

— Polimero estruso resistente agli urti, formato da una miscela di polistirene ad alta densità
— Polímero extrudido, resistente a impactos, com base numa mistura de poliestireno de alta densidade

Detail Design ☆☆

— بوليمر مبثوق ومقاوم للصددمات، من مزيج بوليستيرين عالي الكثافة

— Un polymère extrudé résistant aux impacts à base d'un mélange de polystyrènes haute densité.

Impact Resistance ☆☆☆



DUROFOAM®

An extruded lightweight polymer based on a low-density polystyrene blend.

— Polimero leggero estruso, formato da una miscela di polistirene di bassa densità
— Polímero extrudido, leve, baseado numa mistura de poliestireno de baixa densidade

Detail Design ☆

— بوليمر مبثوق وخفيف الوزن، من مزيج بوليستيرين متوسط الكثافة

— Un polymère léger extrudé à base d'un mélange de polystyrènes de densité basse.

Impact Resistance ☆



FLEX

A quality high-density flexible polyurethane.

— Poliuretano flessibile ad alta densità e di alta qualità
— Espuma de poliuretano flexível de alta densidade e alta qualidade

Detail Design ☆☆☆

— مادة البولي يوريثين المرنة عالية الكثافة عالية الجودة

— Un polyuréthane flexible de haute densité et qualité.

Impact Resistance ☆☆☆

READY TO PAINT

All of our products are ready to paint. Coloured end finishes on demand.

— Tutti i nostri prodotti sono pronti per essere verniciati. Colori su richiesta
— Todos os nossos produtos estão prontos para a pintar. Cores mediante pedido

— جميع منتجاتنا جاهزة للطلاء، ألوان متوفرة عند الطلب
— Tous nos produits sont prêts à peindre. Couleurs sur demande.



VANTAGGI
VANTAGENS
المميزات
AVANTAGES

Advantages



DURABLE

Orac products are designed to last a lifetime. Smart design and high-end technology assure strong and water resistant products.

— I prodotti Orac sono progettati per durare tutta la vita. Il design intelligente e la tecnologia di alta gamma garantiscono prodotti robusti e resistenti all'acqua
— Os produtos Orac são concebidos para durarem toda a vida. O design inteligente e a tecnologia de ponta garantem produtos fortes e resistentes à água

— صممت منتجات ORAC لتدوم مدى الحياة. تصميم ذكي وتكنولوجيا متطورة تضمن منتجات قوية ومقاومة للماء.

— Les produits sont conçus pour durer toute une vie. Une conception intelligente et une technologie haut de gamme garantissent des produits robustes et résistants à l'eau.

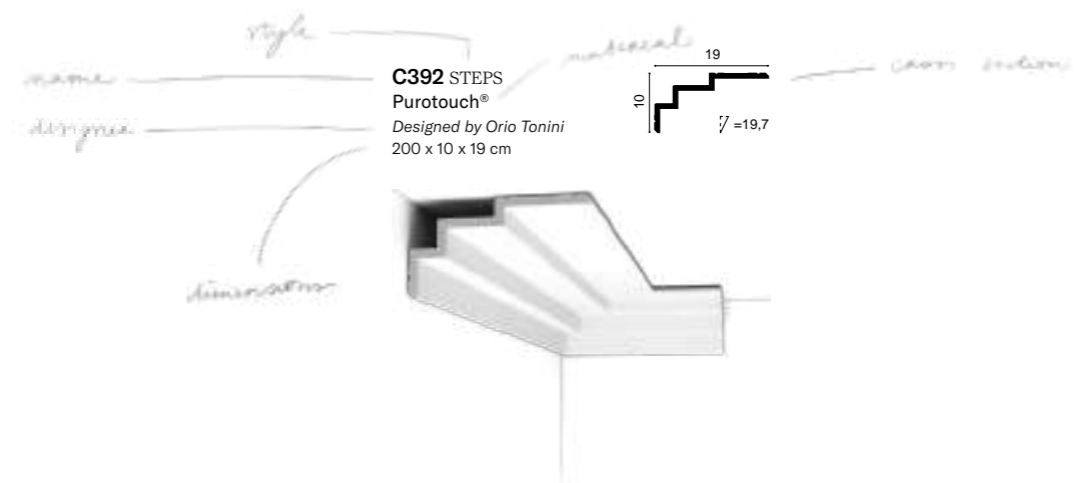

Legend

At Orac, our vision is to become restorative by 2050. This ambitious goal drives our material choices and operational practices, ensuring that every step we take not only minimizes environmental harm but actively contributes to ecological restoration. Since 2018 we have been making profound changes in the full lifecycle of our products. From selection and use of raw materials all the way to our production process.

— There are many sides to walls. We go for the good side.

IT —

In Orac, la nostra visione è quella di diventare restauratori entro il 2050. Questo obiettivo ambizioso guida le nostre scelte di materiali e di pratiche operative, assicurando che ogni nostra azione non solo riduca al minimo i danni ambientali, ma contribuisca attivamente al ripristino ecologico. Dal 2018 abbiamo effettuato cambiamenti profondi nell'intero ciclo di vita dei nostri prodotti. Dalla selezione e dall'uso delle materie prime fino al nostro processo produttivo, le pareti hanno molti lati. Noi cerchiamo il lato positivo.

PT —

Na Orac, a nossa ambição é ter impacto positivo no ambiente até 2050. Este ambicioso objetivo tem guiado as nossas escolhas de materiais e optado pelas melhores práticas operacionais, assegurando que cada passo que damos, não só minimiza os danos ambientais, mas também contribui, ativamente, para a preservação da pegada ecológica. Desde 2018, temos vindo desenvolver alterações profundas em todo o ciclo de vida dos nossos produtos. Desde a seleção e utilização das matérias-primas até à produção. As paredes têm muitos lados. Nós escolhemos o melhor.

AR —

رؤيتنا في أورك هي أن نصبح مصلحين بحلول عام 2050 هذا الهدف الطموح يوجه اختيارنا للمواد وممارساتنا التشغيلية، ويضمن أن كل خطوة نتخذها لا تقلل من الضرر البيئي فحسب، بل تساهم أيضًا في ترميم البيئة. منذ عام 2018، أجرينا تغييرات عميقة في دورة الحياة الكاملة لمنتجاتنا. من اختيار واستخدام المواد الخام إلى عملية الإنتاج. الجدران لها جوانب عديدة. نختار الجانب الإيجابي.

FR —

Chez Orac, notre vision est de devenir réparateur d'ici à 2050. Cet objectif ambitieux oriente nos choix de matériaux et nos pratiques opérationnelles, en veillant à ce que chaque mesure que nous prenons non seulement minimise les dommages à l'environnement, mais contribue aussi activement à la restauration écologique. Depuis 2018, nous avons fait de changements profonds au cycle de vie complet de nos produits. De la sélection et de l'utilisation des matières premières jusqu'à notre processus de production. — Les murs ont beaucoup de côtés. Nous choisissons le bon côté.



BIOCIRCULAR MATERIALS
Orac's designs merge recycled and bio-based materials, emphasizing sustainable innovation.



SUSTAINABLE OPERATIONS
Orac has been CO₂ neutral since 2021, working towards climate positivity by 2050.



BUILT TO LAST, BUILT RESPONSIBLY
Our durable products with a lasting lifetime support a sustainable, circular economy.



MORE THAN WALLS
Orac's commitment to sustainability extends to community engagement and social responsibility.

Product overview

- 01 Cornice mouldings
- 02 3D Wall covering
- 03 Skirting boards
- 04 Panel mouldings
- 05 Indirect lighting
- 06 Deco elements
- 07 The perfect finish
- 08 Flexible products



01 p. 64

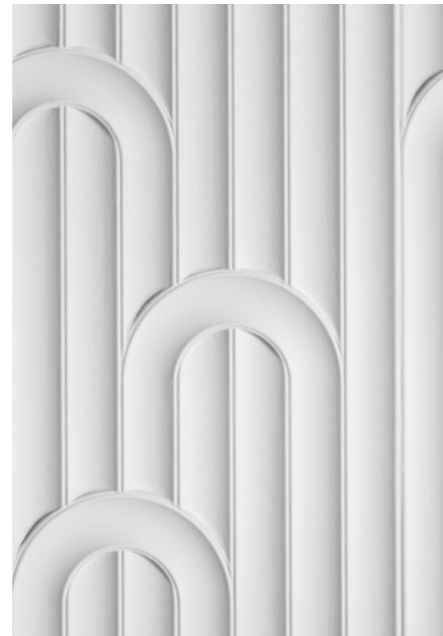

02 p. 92



03 p. 108



04 p. 122



05 p. 134



06 p. 148



07 p. 158



08 p. 162

Cornice Mouldings

ORAC

Products

01

CORNICI SOFFITTO
SANCAS
كرانش
CORNICHES

It truly does move us when we look up and see how it softens the strict transition between wall and ceiling. For us, a cornice is about attention to detail, be it from ornate to subtle. We have thought them all through so that there should always be an option that meets your personal aspirations.

IT –
Ci commuove davvero. Quando guardiamo in alto e vediamo come segue la rigida transizione tra parete e soffitto. Per noi, una cornice è una questione di attenzione ai dettagli. Dall'ornato al sottile. Abbiamo pensato a tutto. In modo che ci sia sempre un'opzione in grado di soddisfare i vostri desideri personali.

PT –
É um orgulho. Quando olhamos para cima e vemos como se suaviza a difícil transição entre a parede e o teto. Para nós, a sanca é uma questão de atenção aos detalhes. Das mais ornamentadas às mais subtis. Pensamos em tudo. Para que haja sempre uma opção que vá ao encontro da sua criatividade.

AR –
نتأثر حقًا عندما ننظر للأعلى ونرى كيف تلطف الانتقال بين الجدار والسقف. بالنسبة لنا، تعبير الكرانيش عن اهتمام بالتفاصيل. من المزخرفة إلى الخفية. لقد فكرنا بها كلها، كي يكون هناك دائمًا خيارًا يلبي تطلعاتكم الشخصية.

FR –
C'est véritablement captivant. En levant les yeux, on remarque comment elle adoucit la transition stricte entre le mur et le plafond. Pour nous, une corniche incarne un souci minutieux du détail, que ce soit dans l'ornementation ou dans la subtilité. Chaque option a été soigneusement pensée pour répondre à vos aspirations personnelles.

C341 | C341F HERITAGE Purotouch®
200 x 8,8 x 12,2 cm

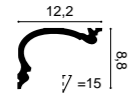

C342 HERITAGE Purotouch®
200 x 14 x 19 cm

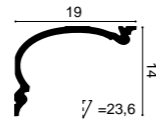

1. C343 HERITAGE Purotouch®
200 x 19 x 25 cm

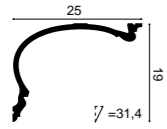

C344 HERITAGE Purotouch®
200 x 27,3 x 35 cm

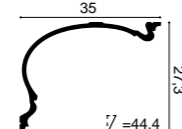

1. C343 2. P8020 p.124



Cornice moldings

1. C327 2. P8030 p.124 3. P8020 p.124 4. SX191 p.115

C325 MANOIR Purotouch®
200 x 7 x 6,5 cm

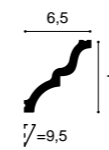

C326 MANOIR Purotouch®
200 x 10,5 x 9 cm

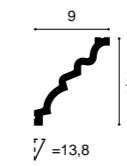

C327 MANOIR Purotouch®
200 x 14,3 x 15,9 cm

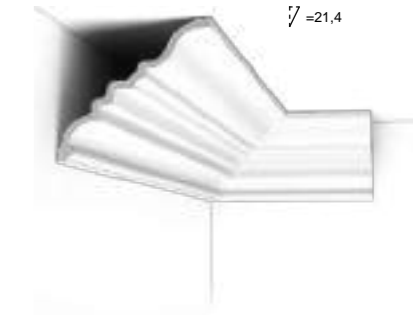
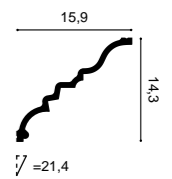

C338 BA'ROCK
Purotouch®
200 x 18,2 x 18,2 cm

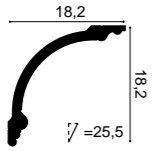

C338A BA'ROCK
Purotouch®
200 x 18,2 x 18,2 cm
Dessin: 120 cm

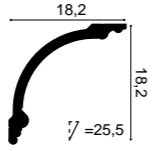

C338B BA'ROCK
Purotouch®
200 x 18,2 x 18,2 cm
Dessin: 2 x 57 cm

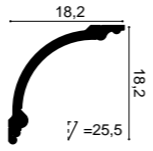

C336 BA'ROCK
Purotouch®
200 x 27,1 x 26,6 cm

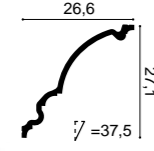

1. C217



C230 | C230F
Purotouch®
200 x 2,9 x 2,9 cm

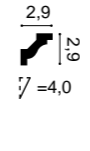

C215 | C215F
Purotouch®
200 x 4,7 x 4,7 cm

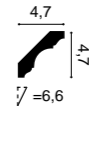

C322
Purotouch®
200 x 5 x 4,2 cm

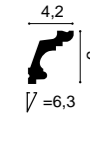

C200
Purotouch®
200 x 6,5 x 5,7 cm

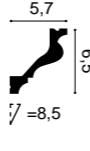

C220 | C220F
Purotouch®
200 x 7,6 x 11,6 cm

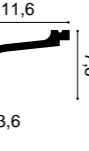

C213 | C213F
Purotouch®
200 x 8 x 8 cm

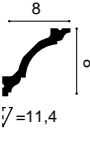

① **C217 | C217F**
Purotouch®
200 x 15,6 x 10,3 cm

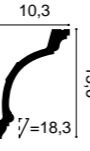

C217 | C217F ↻ 90°
Purotouch®
200 x 10,3 x 15,6 cm

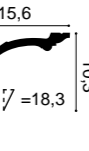

C216
Purotouch®
200 x 11,6 x 13,3 cm

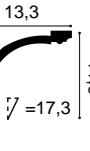

C301
Purotouch®
200 x 17 x 14,4 cm

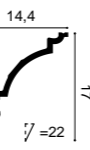

C305
Purotouch®
200 x 4,7 x 15,5 cm

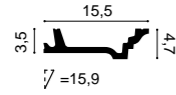

C305 + C213

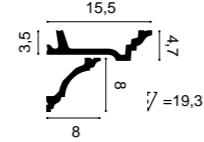

C305 + C211

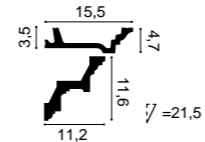

C211 | C211F
Purotouch®
200 x 11,6 x 11,2 cm

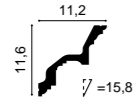

C422
Purotouch®
200 x 16,4 x 19,4 cm

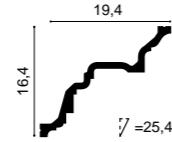

C307
Purotouch®
200 x 19,5 x 19,5 cm

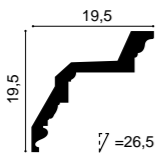

(A) C307 + C307A (B)
Purotouch®
Duropolymer®
C307A: 7,5 x 4 x 9,4 cm

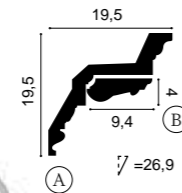

Cornice moldings

1. PX175 p.129 2. C305 3. C307A 4. C211 5. P8030 p.124 6. SX191 p.115

C333 | C333F
Purotouch®
200 x 12,2 x 11,1 cm

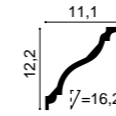

C331 | C331F
Purotouch®
200 x 6,4 x 13,5 cm

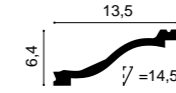

C334 | C334F
Purotouch®
200 x 15 x 19,6 cm

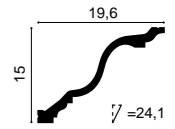

C902 | C902F
Purotouch®
200 x 10,3 x 10,3 cm

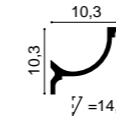

C901 | C901F
Purotouch®
200 x 14,8 x 12,4 cm

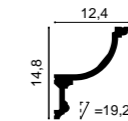

C900
Purotouch®
200 x 17,1 x 14,6 cm

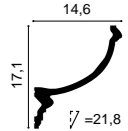

C212
Purotouch®
200 x 7,5 x 4,5 cm

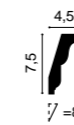

C201
Purotouch®
200 x 11,6 x 4,8 cm



C304 | C304F
Purotouch®
200 x 12,2 x 7,2 cm



C303
Purotouch®
200 x 14,4 x 6,5 cm



C219
Purotouch®
200 x 17,6 x 13 cm

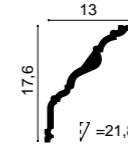

1. C219



C321 | C321F
Purotouch®
200 x 9,9 x 5 cm

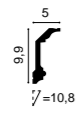

C339 | C339F
Purotouch®
200 x 14,1 x 6,4 cm

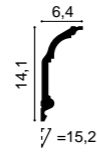

C332
Purotouch®
200 x 23 x 11,4 cm

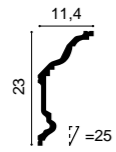

C332 90°
Purotouch®
200 x 11,4 x 23 cm

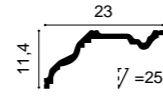

C340
Purotouch®
200 x 25,6 x 13,5 cm

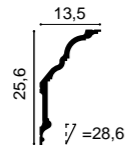

C340 90°
Purotouch®
200 x 13,5 x 25,6 cm

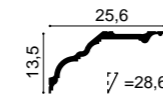

1. C332 2. P8020 p.124 3. SX118 p.111



Cornice moldings

the perfect finish

PG. 158 -161

C250 | C250F
Purotouch®
200 x 1,6 x 1,6 cm

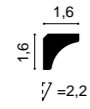

C260
Purotouch®
200 x 4,1 x 4,8 cm

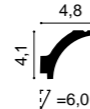

C240 | C240F
Purotouch®
200 x 8 x 8 cm

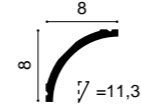

¹ C990 + 2x CX188 p.142



C991
Purotouch®
200 x 14 x 11 cm
Designed by Ulf Moritz

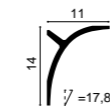

C991 + P9900

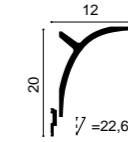

C991 + 2x P9900

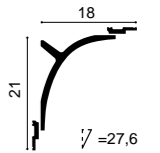

¹ C991 90°
Purotouch®
200 x 11 x 14 cm
Designed by Ulf Moritz

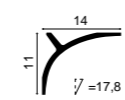

C991 + P9900 90°

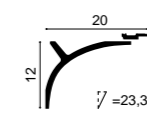

C991 + 2x P9900 90°

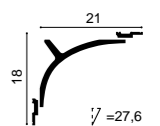

C990 INFINITY
Purotouch®
200 x 21,6 x 15,9 cm
Designed by Xavier Donck

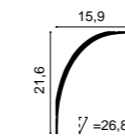

C990 + P9900

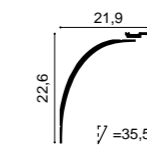

C990 + 2x P9900

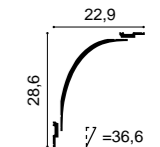

C990 INFINITY 90°
Purotouch®
200 x 15,9 x 21,6 cm
Designed by Xavier Donck

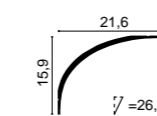

C990 + P9900 90°

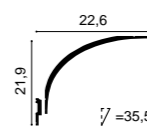

C990 + 2x P9900 90°

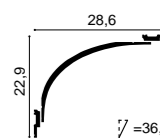

Steps

ORAC

Products



CORNICE MOULDINGS | CORNICI SOFFITTO | SANCAS | کرانش | CORNICHES

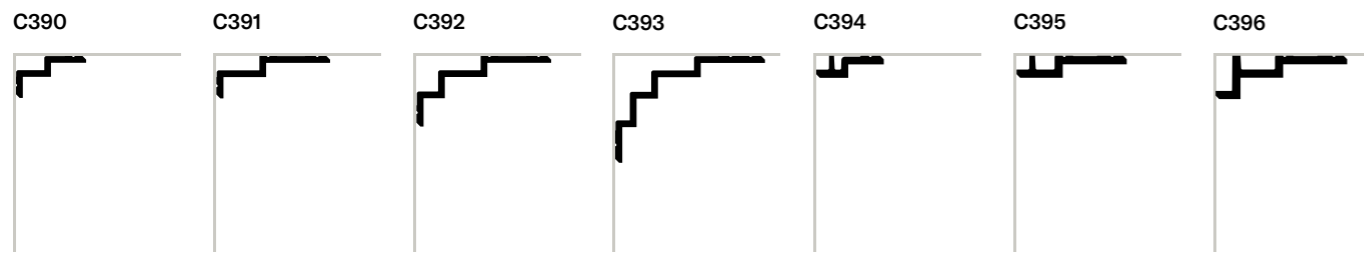

BORDER

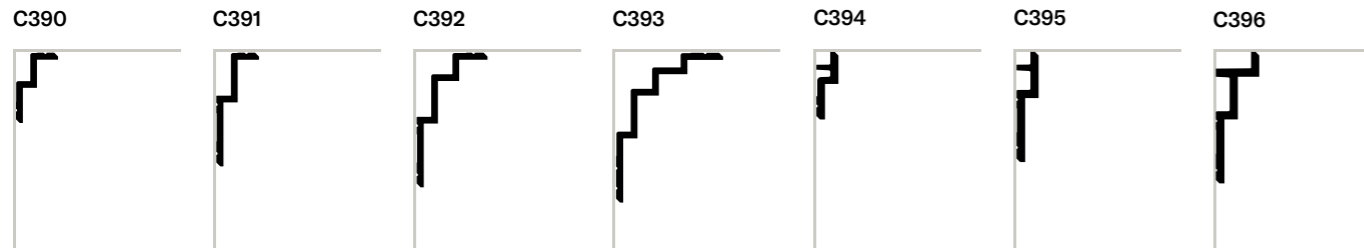

CURTAIN PROFILES | PROFILI PER TENDE | SANCAS PARA CORTINADOS | سلك الستائر | PROFILS RIDEAU

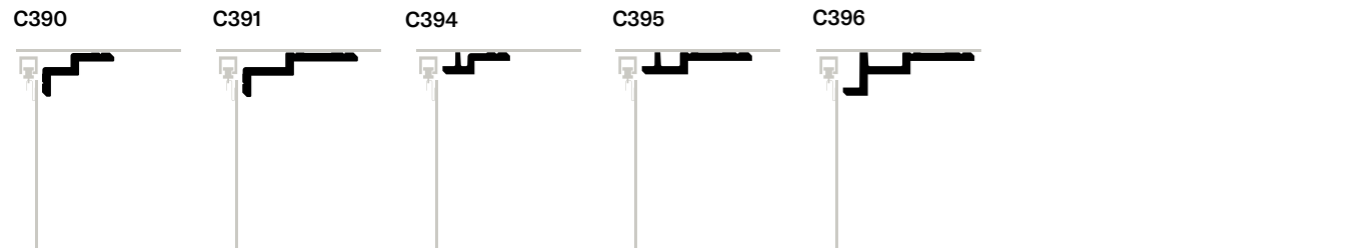

INDIRECT LIGHTING | ILLUMINAZIONE INDIRETTA | ILUMINAÇÃO INDIRETA | إضاءة غير مباشرة | ÉCLAIRAGE INDIRECT

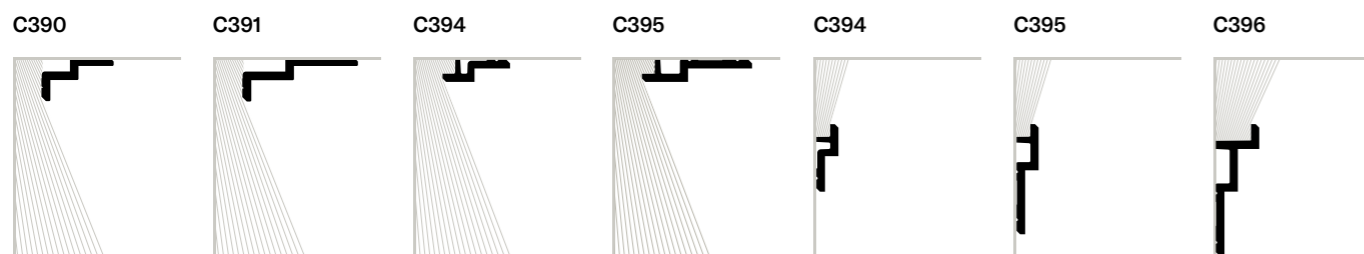

Downlighter

Uplighter

C394 STEPS
Purotouch®
200 x 9,5 x 3,1 cm
Designed by Orio Tonini

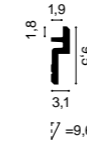

C395 STEPS
Purotouch®
200 x 15,5 x 3,1 cm
Designed by Orio Tonini



C396 STEPS
Purotouch®
200 x 18,5 x 6,1 cm
Designed by Orio Tonini

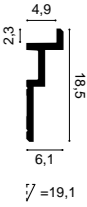

C390 STEPS
Purotouch®
200 x 6 x 10 cm
Designed by Orio Tonini



C391 STEPS
Purotouch®
200 x 6 x 16 cm
Designed by Orio Tonini

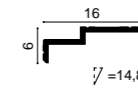

C392 STEPS
Purotouch®
200 x 10 x 19 cm
Designed by Orio Tonini

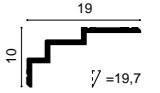

C393 STEPS
Purotouch®
200 x 15 x 21 cm
Designed by Orio Tonini

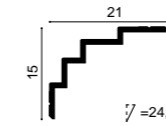

1. C391 2. C393



Cornice mouldings

C360
Purotouch®
200 x 2,1 x 6 cm
Designed by Jacques Vergracht

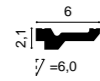

C356
Purotouch®
200 x 2 x 10 cm
Designed by Jacques Vergracht

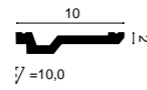

C355
Purotouch®
200 x 3,5 x 11,1 cm
Designed by Jacques Vergracht

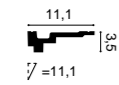

C353
Purotouch®
200 x 3 x 16,5 cm
Designed by Jacques Vergracht

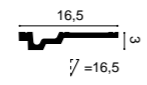

C354
Purotouch®
200 x 4 x 21,5 cm
Designed by Jacques Vergracht

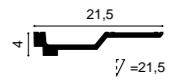

C602
Purotouch®
200 x 5,3 x 5 cm



C400
Purotouch®
200 x 6 x 10 cm



¹ C355 ² C991 p.77

Curtain profiles

PROFILI PER TENDE
SANCAS PARA CORTINADOS
سكك الستائر
PROFILS RIDEAU



ORAC

1. C340

Products

**C394 STEPS
CURTAIN PROFILE**
Purotouch®
200 x 3,1 x 9,5 cm
Designed by Orio Tonini

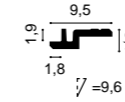

**C395 STEPS
CURTAIN PROFILE**
Purotouch®
200 x 3,1 x 15,5 cm
Designed by Orio Tonini

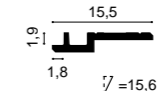

**C390 STEPS
CURTAIN PROFILE**
Purotouch®
200 x 6 x 10 cm
Designed by Orio Tonini

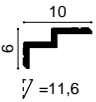

**C391 STEPS
CURTAIN PROFILE**
Purotouch®
200 x 6 x 16 cm
Designed by Orio Tonini

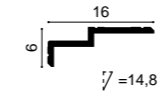

**C396 STEPS
CURTAIN PROFILE**
Purotouch®
200 x 6,1 x 18,5 cm
Designed by Orio Tonini

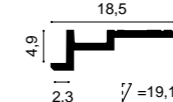

**C991
CURTAIN PROFILE**
Purotouch®
200 x 11 x 14 cm
Designed by Ulf Moritz

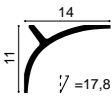

**C341 | C341F HERITAGE
CURTAIN PROFILE**
Purotouch®
200 x 8,8 x 12,2 cm

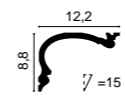

**C342 HERITAGE
CURTAIN PROFILE**
Purotouch®
200 x 14 x 19 cm

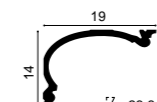

**C343 HERITAGE
CURTAIN PROFILE**
Purotouch®
200 x 19 x 25 cm

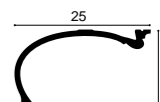

**C340
CURTAIN PROFILE**
Purotouch®
200 x 13,5 x 25,6 cm

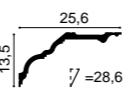

**CX196 U-STEPS
CURTAIN PROFILE**
Duropolymer®
200 x 4 x 11,3 cm
Designed by Orio Tonini

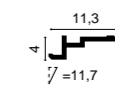

**CX197 U-STEPS
CURTAIN PROFILE**
Duropolymer®
200 x 5 x 9,3 cm
Designed by Orio Tonini

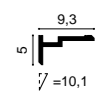

Cornice mouldings

CX124 | CX124F
Duropolymer®
200 x 4,9 x 4,9 cm

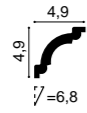

CX100 | CX100F
Duropolymer®
200 x 6,9 x 7,1 cm

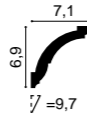

CX123 | CX123F
Duropolymer®
200 x 8 x 8 cm

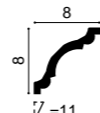

③ CX111
Duropolymer®
200 x 2,6 x 1,5 cm



CX110 | CX110F
Duropolymer®
200 x 4,5 x 4,1 cm

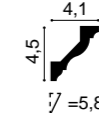

CX127 | CX127F
Duropolymer®
200 x 9,4 x 9,4 cm

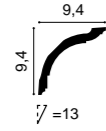

CX199 | CX199F
Duropolymer®
200 x 8 x 8 cm

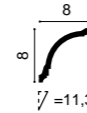

CX106 | CX106F
Duropolymer®
200 x 11,8 x 11,7 cm

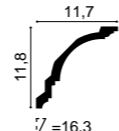

CX108
Duropolymer®
200 x 5,4 x 5,5 cm

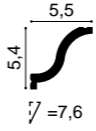

CX112
Duropolymer®
200 x 5,4 x 3,8 cm

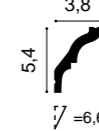

CX177
Duropolymer®
200 x 7 x 6 cm



1. P8030 p.124 2. P8020 p.124 3. CX110

CX203
Duropolymer®
200 x 14,5 x 14,5 cm

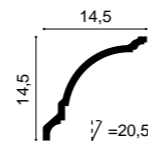

CX129
Duropolymer®
200 x 9,4 x 9,4 cm

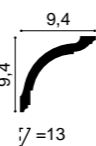

CX107
Duropolymer®
200 x 11,8 x 11,7 cm

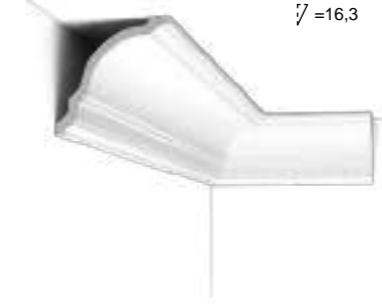
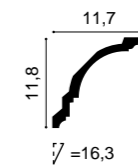

the perfect finish



CX133
Duropolymer®
200 x 2 x 2 cm



CX132
Duropolymer®
200 x 2 x 2 cm



CX115
Duropolymer®
200 x 3 x 2,9 cm



① **CX190 | CX190F U-PROFILE**
Duropolymer®
200 x 2 x 3 cm
Designed by Orio Tonini

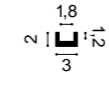

CX109 | CX109F
Duropolymer®
200 x 4,4 x 4,4 cm

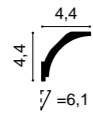

CX126
Duropolymer®
200 x 8,7 x 8,7 cm

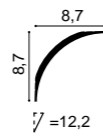

CX196 U-STEPS
Duropolymer®
200 x 11,3 x 4 cm
Designed by Orio Tonini

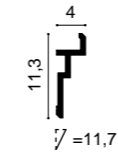

CX148
Duropolymer®
200 x 4,3 x 2,9 cm

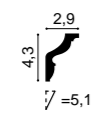

CX141
Duropolymer®
200 x 5,9 x 3,1 cm

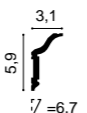

CX176
Duropolymer®
200 x 8 x 4 cm



CX197 U-STEPS
Duropolymer®
200 x 9,3 x 5 cm
Designed by Orio Tonini

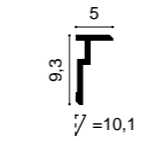

CX192
Duropolymer®
200 x 12 x 6 cm

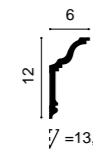

② **PX198 | PX198F U-STEPS**
Duropolymer®
200 x 8,3 x 2 cm
Designed by Orio Tonini



PX198 | PX198F U-STEPS 90°
Duropolymer®
200 x 2 x 8,3 cm
Designed by Orio Tonini

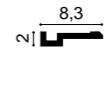

1. CX190F 2. PX198F 3. W111F p.101 4. W116F p.101 5. W119F p.101



Cornice mouldings

¹ CX192 p.86 ² P8030 p.124



SX194 | SX194F SQUARE
 Duropolymer®
 200 x 1 x 2 cm



SX162 | SX162F SQUARE
 Duropolymer®
 200 x 1 x 4 cm



SX157 | SX157F SQUARE
 Duropolymer®
 200 x 1,3 x 6,6 cm



SX163 | SX163F SQUARE
 Duropolymer®
 200 x 1,3 x 10,1 cm



SX182 | SX182F CASCADE
 Duropolymer®
 200 x 1,3 x 5 cm



SX183 | SX183F CASCADE
 Duropolymer®
 200 x 1,3 x 7,5 cm



SX184 | SX184F CASCADE
 Duropolymer®
 200 x 1,3 x 11 cm



CX160
 Duropolymer®
 200 x 1,3 x 3,9 cm



CX161
 Duropolymer®
 200 x 1,3 x 6,9 cm



the perfect finish



CB500N
Durofoam®
200 x 2,5 x 1,8 cm

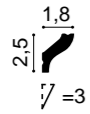

CB501N
Durofoam®
200 x 4,1 x 3,5 cm

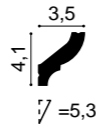

CB502N
Durofoam®
200 x 5,9 x 4,9 cm

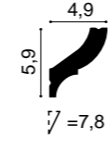

CB503N
Durofoam®
200 x 8,2 x 9,2 cm

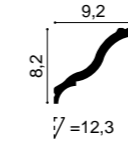

CB520N
Durofoam®
200 x 3,5 x 3,5 cm

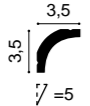

CB521N
Durofoam®
200 x 5 x 5 cm

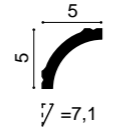

CB522N
Durofoam®
200 x 6,7 x 6,7 cm

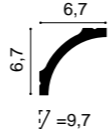

CB524N
Durofoam®
200 x 9 x 9 cm

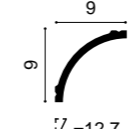

CB525N
Durofoam®
200 x 6,5 x 6 cm

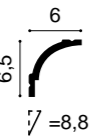

CB523N
Durofoam®
200 x 5,9 x 4,4 cm

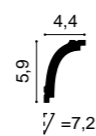

CB510N
Durofoam®
200 x 4 x 4 cm

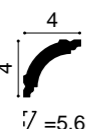

CB511N
Durofoam®
200 x 6,7 x 6,7 cm



CB512N
Durofoam®
200 x 9 x 9 cm

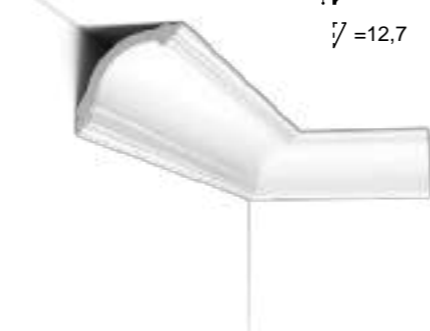
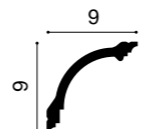

1. CB512N 2. PX103 p.129

3D Wall covering

ORAC

Products

02

RIVESTIMENTO MURALE 3D
REVESTIMENTO DE PAREDE 3D
تغطية للجدران ثلاثية الأبعاد
REVÊTEMENTS MURAUX 3D

We invite you to experience the extraordinary with our 3D wall coverings. Captivating sculptural landscapes, these masterpieces redefine your walls, inviting touch and exploration. Discover a range of bold and subtle designs, each a testament to the art of interior transformation.

IT—

Passate dall'ordinario allo straordinario grazie ai nostri rivestimenti murali in 3D, se lo desiderate. Realizzazioni scultoree ed accattivanti. Questi capolavori ridefiniscono le pareti, invitando al tatto e all'esplorazione. Esplorate una gamma di design audaci e sottili, ognuno dei quali testimonia l'arte della trasformazione degli interni.

PT—

Viva uma experiência extraordinária com os nossos revestimentos de parede em 3D, se assim o desejar. Paisagens cativantes e esculturais. Estas obras-primas redefinem as suas paredes, convidam ao toque e a explorar mais. Uma gama de designs arrojados e subtis, cada um deles um testemunho da arte de transformar interiores.

AR—

إن أحببتكم، استمتعوا بتجربة غير عادية مع ألواح الجدران ثلاثية الأبعاد المميزة لدينا. منحوتات فائقة تعيد هذه التحف الفنية تشكيل جدرانكم، وتدعوكم إلى اللمس والاستكشاف. استكشفوا مجموعة من التصميمات الجريئة والدقيقة، والتي يمثل كل منها شهادة على فن التحول الداخلي.

FR—

Faites l'expérience de l'extraordinaire avec nos revêtements muraux 3D si vous le souhaitez. Des paysages sculpturaux captivants. Ces chefs-d'œuvre redéfinissent vos murs, invitant au toucher et à l'exploration. Découvrez une gamme de designs audacieux et subtils, chacun témoignant de l'art de la transformation intérieure.

— Where art meets science

Duropolymer isn't new to us, but our method is. We have been making profound changes in the full lifecycle of this product. We are merging bio-based raw materials with recycled elements to create this 100% biocircular masterpiece. And we've got the ISCC certification* to prove it (for the biobased share).



IT —
Dove l'arte incontra la scienza. Il duropolimero non è una novità per noi, ma lo è il nostro metodo. Abbiamo apportato profondi cambiamenti nell'intero ciclo di vita di questo prodotto. Stiamo unendo materie prime a base biologica con elementi riciclati per creare questo capolavoro 100% biocircolare. E abbiamo la certificazione ISCC* che lo dimostra (per la quota biologica).

PT —
A gama Duropolymer não é nova para nós, mas o método de fabrico é. Temos vindo a efetuar mudanças profundas em todo o ciclo de vida deste produto. Estamos a fundir matérias-primas de base biológica com elementos reciclados para criar esta obra-prima 100% biocircular. E temos a certificação ISCC* como prova (para a parte de base biológica).

AR —
حيث يلتقي الفن بالعلم. إن مادة DUROPOLYMER ليست جديدة بالنسبة لنا، لكن طريقتنا جديدة. لقد أجرينا تغييرات عميقة في دورة الحياة الكاملة لهذا المنتج. نحن نقوم بدمج المواد الخام الحيوية مع العناصر المعاد تدويرها لإنشاء هذه التحفة الصديقة للبيئة 100%. وقد حصلنا على شهادة ISCC* لإثبات ذلك (بما يخص نسبة المواد الحيوية).

FR —
Le duropolymer n'est pas une nouveauté pour nous, mais notre nouvelle méthode l'est. Nous avons fait des changements profonds dans le cycle de vie complet de ce produit. Nous fusionnons des matières premières biosourcées avec des éléments recyclés (issus de déchets post-consommation et post-industriels) pour créer ce chef-d'œuvre 100% biocirculaire. Et nous avons la certification ISCC* pour le prouver. Cette nouvelle ère de décoration éco-responsable est là où l'art rencontre la science.

Products

WX204 | WX204-2600 RIPPLE
Duropolymer®
200 x 25 x 1,6 cm
260 x 25 x 1,6 cm

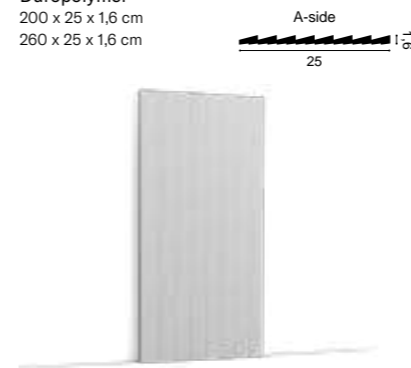

1 WX210 | WX210-2600 | WX210F REED **NEW**
Duropolymer®
200 x 25,5 x 1,2 cm
260 x 25,5 x 1,2 cm

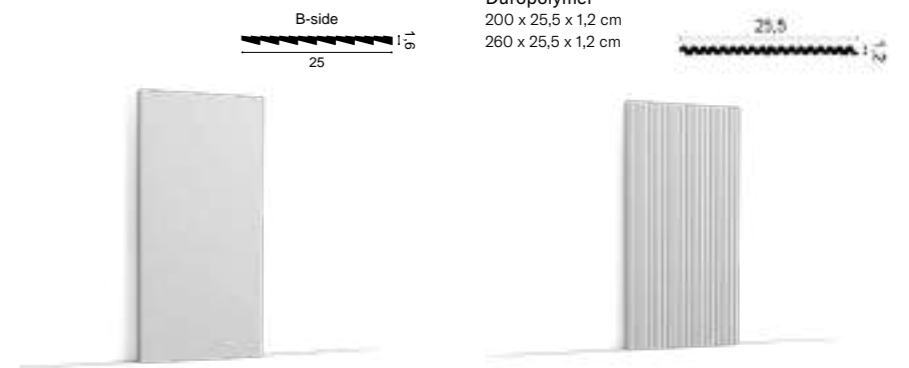

WX205 | WX205-2600 | WX205F TRACK
Duropolymer®
200 x 25 x 1,3 cm
260 x 25 x 1,3 cm

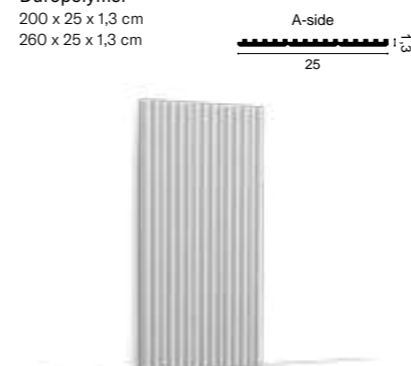

2 WX211 | WX211-2600 | WX211F FLUTE **NEW**
Duropolymer®
200 x 25,5 x 1,7 cm
260 x 25,5 x 1,7 cm

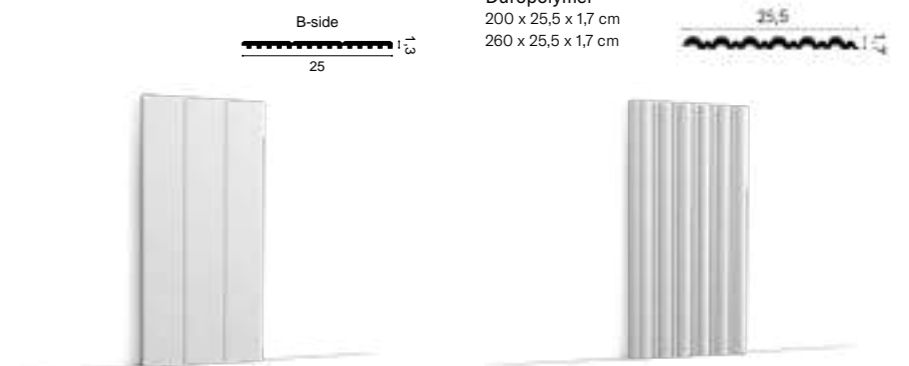

1. WX210 2. WX211

SX207 | SX207F SQUARE
Duropolymer®
200 x 25 x 1,3 cm



3D Wall covering

W108 | W108F ZIGZAG

Purotouch®
200 x 25 x 1,8 cm
Designed by Orio Tonini

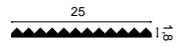

W108 ZIGZAG + 2x CX190



⑤ W110 | W110F HILL

Purotouch®
200 x 25 x 1,6 cm
Designed by Orio Tonini

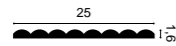

W110 HILL + 2x CX190



② W213 HILL TRACE (NEW)

Purotouch®
200 x 25 x 1,6 cm
Designed by Orio Tonini

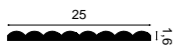

W214 | W214 HILL BEAD XL (NEW)

Purotouch®
200 x 40 x 1,5 cm
Designed by Orio Tonini



W215 HILL BEAD (NEW)

Purotouch®
50 x 80 x 1,5 cm
Designed by Orio Tonini



①

②

③

④

⑤

3D Wall covering

1. PX209 p.131 2. W213 3. WX210 p.95 4. WX211 p.95 5. W110



1. W109 2. PX209 p.131 3. W212

6 W217 PILLOW **NEW**
Purotouch®
200 x 25 x 2,3 cm
Designed by Orio Tonini



4 6 W217 PILLOW + SX182 **NEW**



2. PX209 p.131 4. W217 5. W218 6. SX182 p.111



1 W109 | W109F VALLEY
Purotouch®
200 x 25 x 1,2 cm
Designed by Orio Tonini

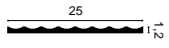

W114 | W114F VALLEY XL
Purotouch®
200 x 25 x 1,5 cm
Designed by Orio Tonini

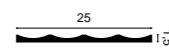

W109 VALLEY + 2x CX190



W114 VALLEY XL + 2x SX194



3 W212 VALLEY LOOP
Purotouch®
200 x 25 x 1,2 cm
Designed by Orio Tonini

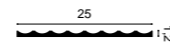

3 W212 VALLEY LOOP + 2x PX209



5 W218 QUILT **NEW**
Purotouch®
200 x 25 x 2,3 cm
Designed by Orio Tonini



5 6 W218 QUILT + SX182 **NEW**



Beyond surface beauty

ACOUSTIC CONTRIBUTION — CLASS E

In combination with other elements, Purotouch has a positive effect on the overall sound quality, absorbing up to 25% of conversational sounds.

THERMAL COMFORT

Purotouch offers thermal insulation akin to specialty insulation boards of the same thickness.

$\lambda = 0,029 \text{ W/mK}$

ECO-CONSCIOUS FROM MATERIAL TO FINISH

Over 11% of Purotouch's composition is biobased, derived from sugar beet & cane. We extend this approach up until the 14% biobased primer paint we use.

IT —

CONTRIBUTO ACUSTICO - CLASSE E
In combinazione con altri elementi, Purotouch ha un effetto positivo sulla qualità complessiva del suono, assorbendo fino al 25% dei suoni di conversazione.

COMFORT TERMICO

Purotouch offre un isolamento termico simile a quello dei pannelli isolanti dello stesso spessore.
 $\lambda = 0,029 \text{ W/mK}$

ECO-CONSAPEVOLE DAL MATERIALE ALLA FINITURA

Oltre l'11% della composizione di Purotouch è a base Biologica, derivato da barbabietola e canna da zucchero. Anche la vernice di fondo (primer) che utilizziamo è al 14% a base Biologica.

AR —

المساهمة الصوتية - الفئة E
بالاقتران مع عناصر أخرى، فإن PUROTOUCH لها تأثير إيجابي على جودة الصوت الإجمالية، حيث تمتص ما يصل إلى 25% من أصوات المحادثة.

الراحة الحرارية
يوفر PUROTOUCH عزل حراري مماثل للألواح العازلة المتخصصة. ألواح العزل بنفس السمك. $\lambda = 0,029 \text{ واط/م كلفن}$

مراعاة للبيئة من المادة إلى النهاية
أكثر من 11% من تركيبة PUROTOUCH ذات أساس حيوي، مشتقة من بنجر السكر وقصب السكر. ونقوم بتوسيع هذا النهج حتى نسبة 14% من الطلاء التمهيدي الحيوي الذي نستخدمه.

PT —

CONTRIBUIÇÃO ACÚSTICA - CLASSE E
Em combinação com outros elementos, o Purotouch ajuda, geralmente, a que haja um efeito positivo na qualidade do som, absorvendo até 25% dos ruídos de fundo.

CONFORTO TÉRMICO

O Purotouch oferece um isolamento térmico semelhante ao das placas de isolamento da mesma espessura.
 $\lambda = 0,029 \text{ W/mK}$

CONSCIÊNCIA AMBIENTAL DESDE A MATERIA PRIMA ATÉ AO ACABAMENTO

Mais de 11% da composição da gama Purotouch é de base biológica, derivada da beterraba e da cana de açúcar. Alargamos este compromisso até à tinta que utilizamos que é 14% à base de produtos de origem biológica.

FR —

CONTRIBUTION ACOUSTIQUE - CLASSE E
En combinaison avec d'autres éléments, Purotouch a un effet positif sur la qualité sonore globale en absorbant jusqu'à 25% des bruits de conversation.

CONFORT THERMIQUE

Purotouch offre une isolation thermique comparable à celle des panneaux d'isolation de la même épaisseur. $\lambda = 0,029 \text{ W/mK}$

ECO-CONSCIENT DU MATÉRIAU À LA FINITION

Plus de 11% de la composition de Purotouch® est biosourcée, dérivée de la betterave et de la canne à sucre. Nous poursuivons cette approche jusqu'à la peinture d'apprêt biosourcée (14%) que nous utilisons.



1. W116 2. W111 3. W119 4. CX190 p.116

② W111 | W111F BAR Purotouch® 200 x 25 x 2 cm Designed by Orio Tonini



① W116 | W116F BAR XL Purotouch® 200 x 25 x 2 cm Designed by Orio Tonini



③ W119 | W119F BAR MIX Purotouch® 200 x 25 x 2 cm Designed by Orio Tonini



② ④ W111 BAR + CX190 + PX198



① ④ W116 BAR XL + CX190 + PX198



③ ④ W119 BAR MIX + CX190 + PX198



② **W115 SLOPE**
Purotouch®
200 x 25 x 2,3

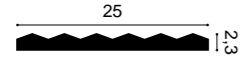

⑤ **W216 MATRIX** **NEW**
Purotouch®
200 x 25 x 1,6 cm
Designed by Orio Tonini

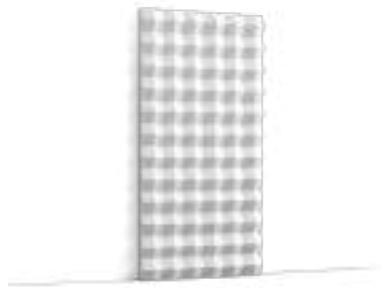

1. CX196 p.142 2. W115 3. CX190 p.116 4. PX198 p.116



5. W216

3D Wall covering

W112 RIDGE
Purotouch®
200 x 25 x 1,9 cm
Designed by Orio Tonini

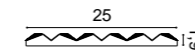

W113 COBBLE
Purotouch®
200 x 25 x 2,2 cm
Designed by Orio Tonini

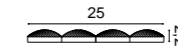

W130 CHEVRON
Purotouch®
200 x 40 x 2 cm

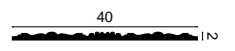

W112 RIDGE + 2x CX190



W113 COBBLE + 2x CX190



W130 CHEVRON + 2x CX190



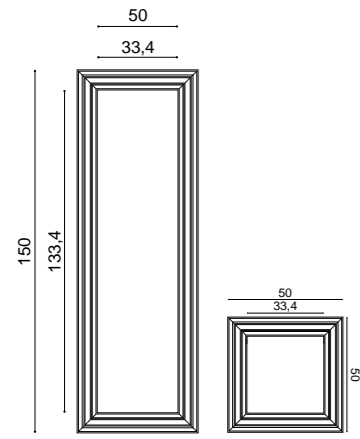

W120 + P4025 + W121
Purotouch®
Designed by Orio Tonini



③ **W120** AUTOIRE
Purotouch®
50 x 150 x 3,2 cm
Designed by Orio Tonini



④ **W121** AUTOIRE
Purotouch®
50 x 50 x 3,2 cm
Designed by Orio Tonini

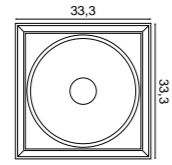

W122 AUTOIRE
Purotouch®
33,3 x 33,3 x 2,6 cm
Designed by Orio Tonini



W120 + 4*W122
Purotouch®
Designed by Orio Tonini

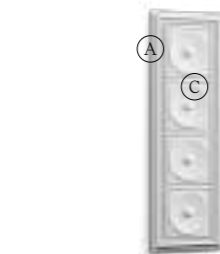

W121 + W122
Purotouch®
Designed by Orio Tonini

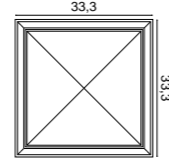
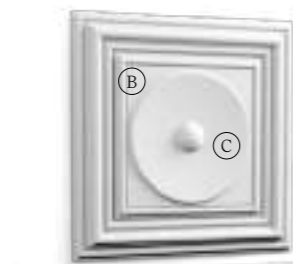

W123 AUTOIRE
Purotouch®
33,3 x 33,3 x 3,5 cm
Designed by Orio Tonini



W120 + 4*W123
Purotouch®
Designed by Orio Tonini

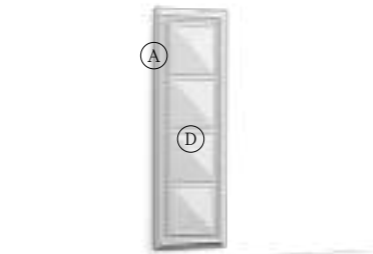

W121 + W123
Purotouch®
Designed by Orio Tonini



1. DX170-2300 p.154 2. D330LR p.154 3. W120 4. W121 5. SX138 p.113



3D Wall covering

W100 ROMBUS
 Purotouch®
 25,8 x 15 x 2,9 cm

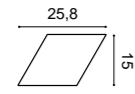

W101 TRAPEZIUM
 Purotouch®
 34,5 x 15 x 2,9 cm

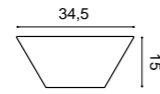

W105 ROMBUS
 Purotouch®
 30 x 34,6 x 3 cm

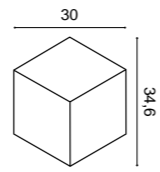

1. W106 2. W107



①

②

① **W106 ENVELOP**
 Purotouch®
 33,3 x 33,3 x 2,9 cm
 Designed by Orio Tonini

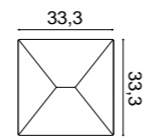

② **W107 CIRCLE**
 Purotouch®
 33,3 x 33,3 x 2,9 cm
 Designed by Orio Tonini

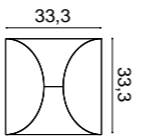

1. F30



①

F30
 Purotouch®
 59,5 x 59,5 x 4,3 cm

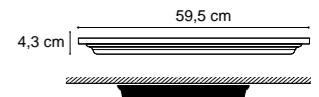

Skirting boards

ORAC

Products

03

BATTISCOPA
RODAPÉS
وزرات
PLINTHES

Crafting seamless transitions from floor to wall, from the elegantly ornate to the gracefully understated. We pay meticulous attention to every detail in every design so you can find options that match your vision.

IT —
Realizzare transizioni senza soluzione di continuità dal pavimento alla superficie, dall'elegante al minimal. Ogni progetto è caratterizzato da un'attenzione meticolosa per i dettagli, in modo che possiate trovare le opzioni che corrispondono alla vostra visione.

PT —
Criando transições suaves entre o piso e a parede, dos mais ornamentados aos mais elegantes. Em cada design, somos meticolosos nos detalhes, para que possa encontrar opções que se enquadrem na sua visão.

AR —
خلق انتقالات سلسة من الأرضية إلى الحائط، من المزخرفة الأنيقة إلى البسيطة. نحن نولي اهتمامًا دقيقًا بالتفاصيل في كل تصميم، كي تتمكنوا من إيجاد الخيارات التي تتوافق مع رؤيتكم.

FR —
La création de transitions harmonieuses entre le sol et la surface, de l'élégamment orné au gracieusement discret. Nous accordons une attention méticuleuse aux détails dans chaque conception, afin que vous puissiez trouver les options qui correspondent à votre vision.

Three cornerstone skirting families

They invite you to create.

IT –
Tre famiglie di battiscopa
Vi invitano a creare

PT –
Três famílias de rodapés
fundamentais
Convidam à criação

AR –
ثلاث عائلات من وزرات الراوية
تدعوكم إلى الإبداع.

FR –
Trois familles de plinthes clés
Une invitation à la créativité



1. SX118 2. PX103 p.129

Products

**SX162 | SX162F |
SX162-RAL9003 SQUARE**
Duropolymer®
200 x 4 x 1 cm



**SX182 | SX182F |
SX182-RAL9003 CASCADE**
Duropolymer®
200 x 5 x 1,3 cm



**SX165 | SX165F |
SX165-RAL9003 CONTOUR**
Duropolymer®
200 x 6,9 x 1,1 cm



**SX157 | SX157F |
SX157-RAL9003 SQUARE**
Duropolymer®
200 x 6,6 x 1,3 cm



**SX183 | SX183F |
SX183-RAL9003 CASCADE**
Duropolymer®
200 x 7,5 x 1,3 cm



**SX173 | SX173F |
SX173-RAL9003 CONTOUR**
Duropolymer®
200 x 10 x 1,6 cm



**SX163 | SX163F |
SX163-RAL9003 SQUARE**
Duropolymer®
200 x 10,1 x 1,3 cm



**SX184 | SX184F |
SX184-RAL9003 CASCADE**
Duropolymer®
200 x 11 x 1,3 cm



**SX118 | SX118F |
SX118-RAL9003 CONTOUR**
Duropolymer®
200 x 13,9 x 1,8 cm



SX171 | SX171-RAL9003 SQUARE
Duropolymer®
200 x 10 x 2,2 cm



SX185 CASCADE
Duropolymer®
200 x 12 x 2,5 cm



SX186 CONTOUR
Duropolymer®
200 x 13,8 x 2,2 cm



Square

Cascade

Contour

small

medium

large

cover

Skirting boards

SX195 | SX195F HAMBURG
Duropolymer®
200 x 8 x 1,9 cm



SX105 | SX105F
Duropolymer®
200 x 11 x 1,3 cm

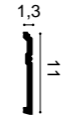

SX155 | SX155F
Duropolymer®
200 x 10,8 x 2,5 cm



1. DX170-2300 p.154 2. P9010 p.124 3. P9050 p.126 4. SX155



1. W120 p.104 2. W121 p.104 3. W122 p.104 4. W123 p.104 5. P4025 p.124 6. SX138 p.113

SX137 | SX137F
Duropolymer®
200 x 10 x 1,5 cm



SX138 | SX138F
Duropolymer®
200 x 13,8 x 1,5 cm



SX206 CONTOUR
Duropolymer®
200 x 18 x 1,8 cm



SX193 AUTOIRE
Duropolymer®
200 x 25 x 2,2 cm
Designed by Orlo Tonini



SX187 | SX187F HIGH LINE
Duropolymer®
200 x 7,5 x 1,2 cm
Designed by Pierre Daems



SX180 | SX180F HIGH LINE
Duropolymer®
200 x 12 x 1,6 cm
Designed by Pierre Daems



SX181 HIGH LINE
Duropolymer®
200 x 20 x 2,2 cm
Designed by Pierre Daems



1- P7070 p.126 2- SX180



Skirting boards

3- W120 p.104 4- W121 p.104 5- SX191

SX104 | SX104F
Duropolymer®
200 x 15 x 1,8 cm



SX156 HIGH HEELS
Duropolymer®
200 x 20,2 x 1,6 cm
Designed by Xavier Donck



SX191 HIGH RISE
Duropolymer®
200 x 21 x 2,1 cm

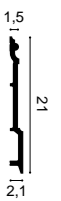

SX194 | SX194F SQUARE
Duropolymer®
200 x 2 x 1 cm



CX132 | CX132F
Duropolymer®
200 x 2 x 2 cm



CX133
Duropolymer®
200 x 2 x 2 cm



③ CX190 | CX190F U-PROFILE
Duropolymer®
200 x 3 x 2 cm
Designed by Orio Tonini



PX198 | PX198F U-STEPS
Duropolymer®
200 x 8,3 x 2 cm
Designed by Orio Tonini



PX198 | PX198F U-STEPS 180°
Duropolymer®
200 x 8,3 x 2 cm
Designed by Orio Tonini



SX159
Duropolymer®
200 x 6 x 1,2 cm



SX125
Duropolymer®
200 x 6,9 x 1,4 cm



SX179 DIAGONAL
Duropolymer®
200 x 9,7 x 2,9 cm
Designed by Orio Tonini

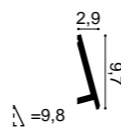

SX172 | SX172F
Duropolymer®
200 x 8,5 x 1,4 cm



SX212 CASCADE NEW
Duropolymer®
200 x 17 x 1,3 cm



¹ C343 p.66 ² P8020 p.124 ³ CX190 ⁴ W109 p.98



Multifunctional

MULTIFUNZIONALE
MULTIFUNCIONAL
تالام عتس إلالا ةددعتم
MULTIFONCTIONNEL

ORAC

Products

PX198 | PX198F U-STEPS
Duopolymer®
200 x 8,3 x 2 cm
Designed by Orio Tonini



PX198 | PX198F U-STEPS 180°
Duopolymer®
200 x 8,3 x 2 cm
Designed by Orio Tonini



SX182 | SX182F CASCADE
Duopolymer®
200 x 5 x 1,3 cm



SX183 | SX183F CASCADE
Duopolymer®
200 x 7,5 x 1,3 cm



SX184 | SX184F CASCADE
Duopolymer®
200 x 11 x 1,3 cm



CX190 | CX190F U-PROFILE
Duopolymer®
200 x 3 x 2 cm
Designed by Orio Tonini



SX159
Duopolymer®
200 x 6 x 1,2 cm



SX187 | SX187F HIGH LINE
Duopolymer®
200 x 7,5 x 1,2 cm
Designed by Pierre Daems



SX180 | SX180F HIGH LINE
Duopolymer®
200 x 12 x 1,6 cm
Designed by Pierre Daems



SX181 HIGH LINE
Duopolymer®
200 x 20 x 2,2 cm
Designed by Pierre Daems



SX194 | SX194F SQUARE
Duopolymer®
200 x 2 x 1 cm



SX162 | SX162F SQUARE
Duopolymer®
200 x 4 x 1 cm



SX157 | SX157F SQUARE
Duopolymer®
200 x 6,6 x 1,3 cm

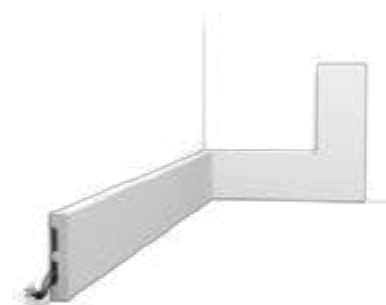

SX163 | SX163F SQUARE
Duopolymer®
200 x 10,1 x 1,3 cm



SX168 SQUARE
Duopolymer®
200 x 15 x 1,3 cm



SX207 | SX207F SQUARE
Duopolymer®
200 x 25 x 1,3 cm



¹ P7070 p.126 ² SX180



We embrace limitless possibilities. Our profiles flow seamlessly from a moulding to a door frame, fostering creativity.

IT —
Abbracciamo possibilità illimitate. I nostri profili si trasformano, da una modanatura a un telaio di una porta, favorendo la creatività.

PT —
Não há limites para a inspiração. Os nossos perfis transformam-se, de um perfil a uma moldura de porta, indo ao encontro da sua criatividade.

AR —
نقدم لكم إمكانيات لا حدود لها. تصاميمنا تتحول، من قالب إلى إطار باب، مما يعزز الإبداع.

FR —
Nous vous offrons des possibilités illimitées. Nos profils se transforment, passant d'une moulure à un cadre de porte, favorisant ainsi la créativité.

1. CX190 p.118



Paintable
 Verniciabile
 Pintável
 يمكن طلاؤها
 Peut être peinte

Water resistant
 Resistente all'acqua
 Resistente à água
 مقاومة للماء
 Résistante à l'eau

Ideal for renovations
 Ideale per le ristrutturazioni
 Ideal para renovações
 مثالية لأعمال الترميم
 Idéale pour les rénovations

2. PX175 p.129 3. SX185

SX171 | SX171-RAL9003 SQUARE
 Duropolymer®
 200 x 10 x 2,2 cm

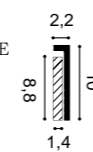

3. **SX185 CASCADE**
 Duropolymer®
 200 x 12 x 2,5 cm

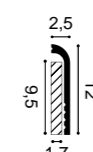

SX186 CONTOUR
 Duropolymer®
 200 x 13,8 x 2,2 cm

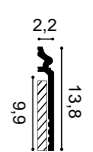

Panel mouldings

ORAC

Products

04

CORNICI PARETE
PERFIS
قوالب للجدران
CIMAISES

An empty wall is like a bare base,
in need of shape and dimension.
Which is why we love to entertain
ideas with these versatile accents.
By using our panel mouldings,
harmony comes into play, a sense
of proportion that is balanced and
pleasing to the eye.

IT —
Una parete vuota è come una base spoglia, bisognosa di forme e dimensioni. Ecco perché ci piace proporre idee versatili. Utilizzando i nostri pannelli 3D restituisce armonia e un senso delle proporzioni equilibrato alle pareti rendendole piacevole alla vista.

PT —
Uma parede vazia é como uma base nua, ansiosa por ganhar forma e dimensão. É por isso que gostamos de explorar a versatilidade dos produtos multifunções. Escolher os nossos painéis é sinónimo de harmonia, uma sensação de equilíbrio que se torna visualmente agradável.

AR —
الجدار الفارغ يشبه القاعدة الفارغة التي تحتاج إلى شكل وأبعاد. لهذا السبب نحب أن نعزز الأفكار الجديدة بهذه اللمسات المتنوعة. استخدام ألواح الجدران يخلق تناغمًا، وشعورًا بالتناسب ممتع للعين.

FR —
Un mur vide ressemble à une page blanche en attente de prendre forme. C'est pourquoi nous aimons infuser de nouvelles idées avec ces accents polyvalents. L'utilisation de nos cimaises permet de créer une harmonie, un équilibre visuellement agréable et bien proportionné.

P8030 | P8030F
Purotouch®
200 x 4,1 x 1,7 cm



② P8020 | P8020F
Purotouch®
200 x 6 x 2,6 cm



③ P8050 | P8050F
Purotouch®
200 x 12 x 3 cm



P1020
Purotouch®
200 x 4,9 x 2,4 cm



P3020 | P3020F
Purotouch®
200 x 6,1 x 3,2 cm



P4020 | P4020F
Purotouch®
200 x 5 x 2,9 cm



P9040
Purotouch®
200 x 5 x 2,5 cm



P9010 | P9010F
Purotouch®
200 x 9,1 x 3 cm



P8040 | P8040F
Purotouch®
200 x 10,1 x 2,2 cm



P4025 | P4025F AUTOIRE
Purotouch®
200 x 8,3 x 3,4 cm
Designed by Orio Tonini

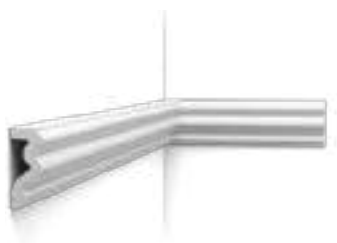

P9020
Purotouch®
200 x 9,6 x 2,1 cm



1. P8050 2. P8020 3. P8030



P6020
Purotouch®
200 x 6,4 x 2,8 cm



P7030
Purotouch®
200 x 8,5 x 1,7 cm



P7020
Purotouch®
200 x 11,1 x 1,9 cm

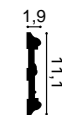

Panel moldings

② **P9050 | P9050F**
Purotouch®
200 x 2,5 x 1,3 cm



P5021 | P5021F
Purotouch®
200 x 3,1 x 0,9 cm



P7070 | P7070F
Purotouch®
200 x 7,4 x 2,2 cm

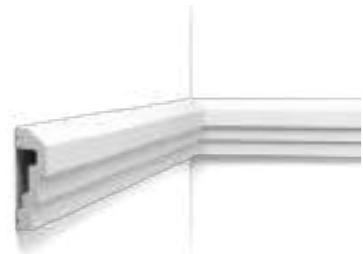

P9900 | P9900F
Purotouch®
200 x 8 x 1 cm

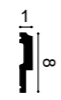

P8060
Purotouch®
200 x 5 x 3,5 cm



P9901
Purotouch®
200 x 7 x 1,4 cm



P3070 RADIUS
Purotouch®
200 x 12,5 x 3,2 cm
Designed by Ulf Moritz

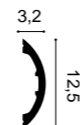

P3071 GOLF
Purotouch®
200 x 37,2 x 7,6 cm
Designed by Ulf Moritz

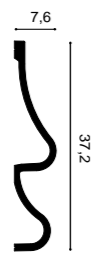

1. P9010 p.124 2. P9050 3. SX155 p.112

DX174-2300 | DX174F
 Duropolymer®
 230 x 6 x 2,2 cm (DX174-2300)
 200 x 6 x 2,2 cm (DX174F)



DX170-2300
 Duropolymer®
 230 x 11,9 x 3,2 cm



DX119-2300
 Duropolymer®
 230 x 9,2 x 2,2 cm



DX121-2300
 Duropolymer®
 230 x 9,4 x 2,3 cm

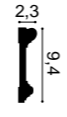

PX103 | PX103F
 Duropolymer®
 200 x 2,5 x 1,2 cm



PX120 | PX120F
 Duropolymer®
 200 x 4 x 1,9 cm

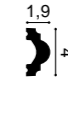

PX201 | PX201F
 Duropolymer®
 200 x 2,5 x 0,9 cm

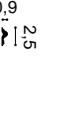

PX175 | PX175F
 Duropolymer®
 200 x 5 x 1,7 cm



PX202 | PX202F
 Duropolymer®
 200 x 7,5 x 2 cm



PX116
 Duropolymer®
 200 x 3,1 x 1 cm

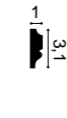

PX117
 Duropolymer®
 200 x 3,5 x 1,5 cm



PX113
 Duropolymer®
 200 x 6 x 2,7 cm



PX144 | PX144F
 Duropolymer®
 200 x 4,7 x 0,8 cm

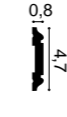

SX159
 Duropolymer®
 200 x 6 x 1,2 cm



¹ P8020 p.124 ² P4020 p.124 ³ SX206 p.113





1. PX209 2. SX207

SX194 | SX194F SQUARE
Duropolymer®
200 x 2 x 1 cm



SX162 | SX162F SQUARE
Duropolymer®
200 x 4 x 1 cm

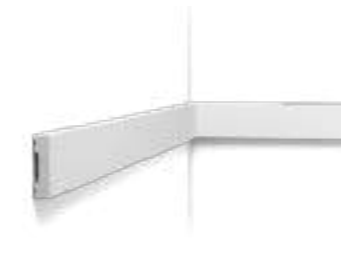

SX157 | SX157F SQUARE
Duropolymer®
200 x 6,6 x 1,3 cm

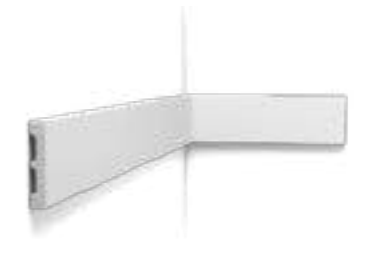

SX163 | SX163F SQUARE
Duropolymer®
200 x 10,1 x 1,3 cm

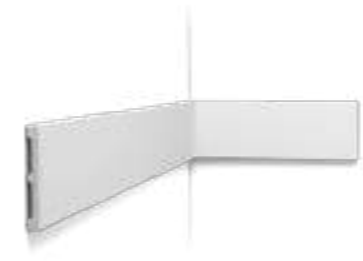

SX168 SQUARE
Duropolymer®
200 x 15 x 1,3 cm



SX207 | SX207F SQUARE
Duropolymer®
200 x 25 x 1,3 cm

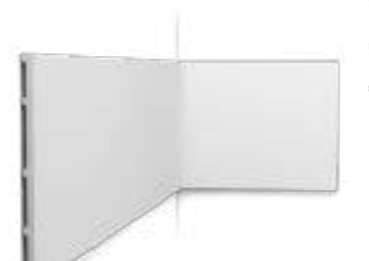

PX169 (A)
Duropolymer®
200 x 5,5 x 3,4 cm

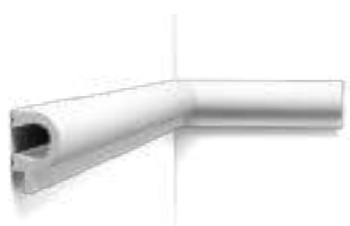

PX147 (B)
Duropolymer®
200 x 16,9 x 0,9 cm



PX169 + PX147



SX182 | SX182F CASCADE
Duropolymer®
200 x 5 x 1,3 cm



SX183 | SX183F CASCADE
Duropolymer®
200 x 7,5 x 1,3 cm



SX184 | SX184F CASCADE
Duropolymer®
200 x 11 x 1,3 cm



CX190 | CX190F U-PROFILE
Duropolymer®
200 x 3 x 2 cm
Designed by Orio Tonini



PX198 | PX198F U-STEPS
Duropolymer®
200 x 8,3 x 2 cm
Designed by Orio Tonini



CX197 U-STEPS
Duropolymer®
200 x 9,3 x 5 cm
Designed by Orio Tonini



SX212 CASCADE (NEW)
Duropolymer®
200 x 17 x 1,3 cm



PX209 | PX209F RIBBON
Duropolymer®
200 x 1 x 1,8 cm
Designed by Orio Tonini



CX134
Duropolymer®
200 x 3 x 3 cm



1- P3020 p.125 2- P3020A 3- P8050 p.124



P101A + P1020
Purotouch®
24,5 x 24,5 x 2,4 cm

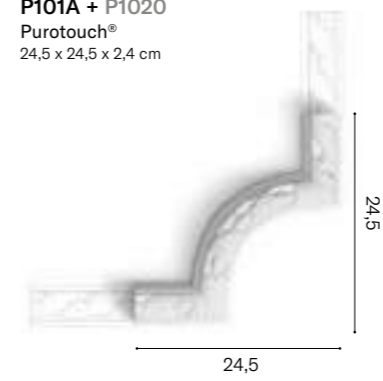

P801C + P8020
Purotouch®
19,8 x 11 x 2,6 cm

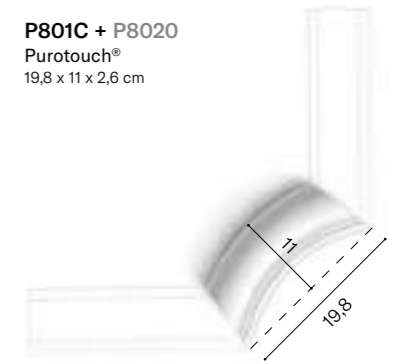

P4020A + P4020
Purotouch®
16,4 x 9,1 x 2,9 cm



P3020A + P3020
Purotouch®
42,5 x 42,5 x 4 cm

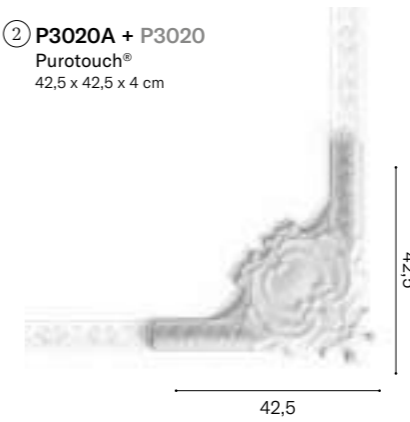

P20 + P101A
Duropolymer®
Ø 6,1 - 0,8 cm

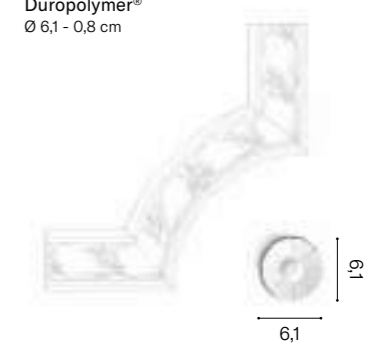

PX103A + PX103
Duropolymer®
19 x 3,5 x 1,5 cm



P8030D + P8030
Duropolymer®
13,2 x 13,2 x 1,7 cm

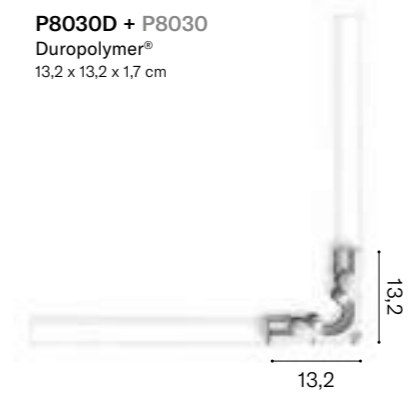

PX120A + PX120
Duropolymer®
19 x 8,8 x 2 cm



P8030C + P8030
Duropolymer®
19 x 8,6 x 1,7 cm

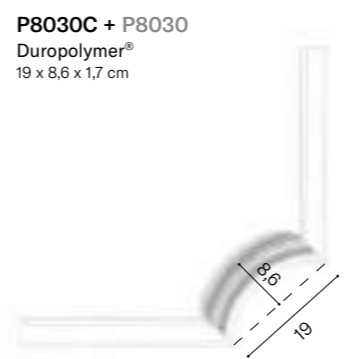

the perfect finish



PG.158-161

Indirect lighting

ORAC

Products

05

ILLUMINAZIONE INDIRETTA
ILUMINAÇÃO INDIRETA
إضاءة غير مباشرة
ÉCLAIRAGE INDIRECT

Our indirect lighting solutions are the unseen maestros of ambiance. They are as versatile as they are subtle, designed to enhance every line and curve. So, we encourage you to integrate them as you see fit, for you to create an atmosphere that complements the time of day and the essence of the moment.

NL—

Le nostre soluzioni di illuminazione indiretta sono i maestri invisibili dell'atmosfera. Sono tanto versatili quanto sottili, progettati per valorizzare ogni linea e curva. Vi invitiamo quindi a integrarli come meglio credete, per creare un'atmosfera che si adatti al momento della giornata e all'essenza del momento.

FR—

As nossas soluções de iluminação indireta são os maestros invisíveis do ambiente. Tão versáteis como subtis, são projetadas para realçar todas as linhas e curvas. Por isso, aconselhamos a sua integração como achar melhor, para que criem uma atmosfera que complemente a hora do dia e a essência do momento.

AR—

الحلول للإضاءة غير المباشرة لدينا هي الماسترو الخفي للأجواء. إنها متعددة الاستخدامات وخفية في آن واحد، ومصممة لتعزيز كل خط ومنحنى. لذلك، نحن نشجعكم على دمجها كما تودون، لتتأكدوا من خلق جو يتناغم مع وقت النهار وجوهر اللحظة.

FR—

Nos solutions d'éclairage indirect sont les maîtres invisibles de l'ambiance. Aussi polyvalentes que subtiles, elles sont conçues pour mettre en valeur chaque ligne et chaque courbe. Nous vous encourageons donc à les intégrer comme bon vous semble, afin de créer une atmosphère qui s'accorde avec l'heure de la journée et l'essence du moment.

② **C323**
Purotouch®
200 x 5,5 x 4,2 cm

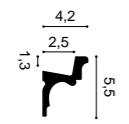

C324 AUTOIRE
Purotouch®
200 x 8,3 x 3,4 cm
Designed by Orio Torini

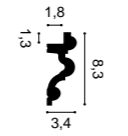

1. W212 p.98 2. C323 3. W109 p.98 4. PX209 p.131 5. SX118 p.111



C357 STRAIGHT
Purotouch®
200 x 7,1 x 11 cm
Designed by Jacques Vergracht

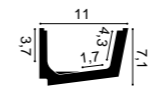

C352 FLAT
Purotouch®
200 x 7,6 x 17,1 cm
Designed by Jacques Vergracht

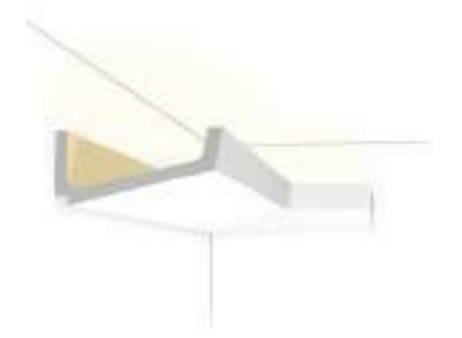
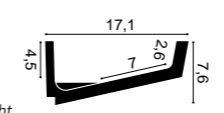

⑥ **C902 | C902F**
Purotouch®
200 x 10,3 x 10,3 cm
Designed by Jacques Vergracht

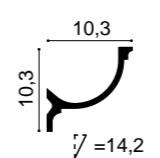

C901 | C901F
Purotouch®
200 x 14,8 x 12,4 cm
Designed by Jacques Vergracht

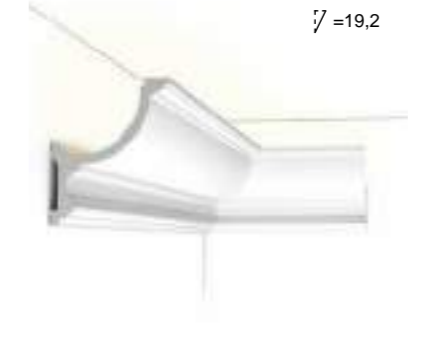
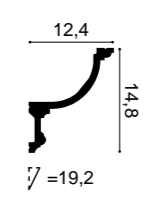

C900
Purotouch®
200 x 17,1 x 14,6 cm
Designed by Jacques Vergracht

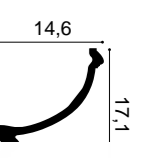

⑥ **C902**

Indirect lighting

L3 lighting combinations

ORAC

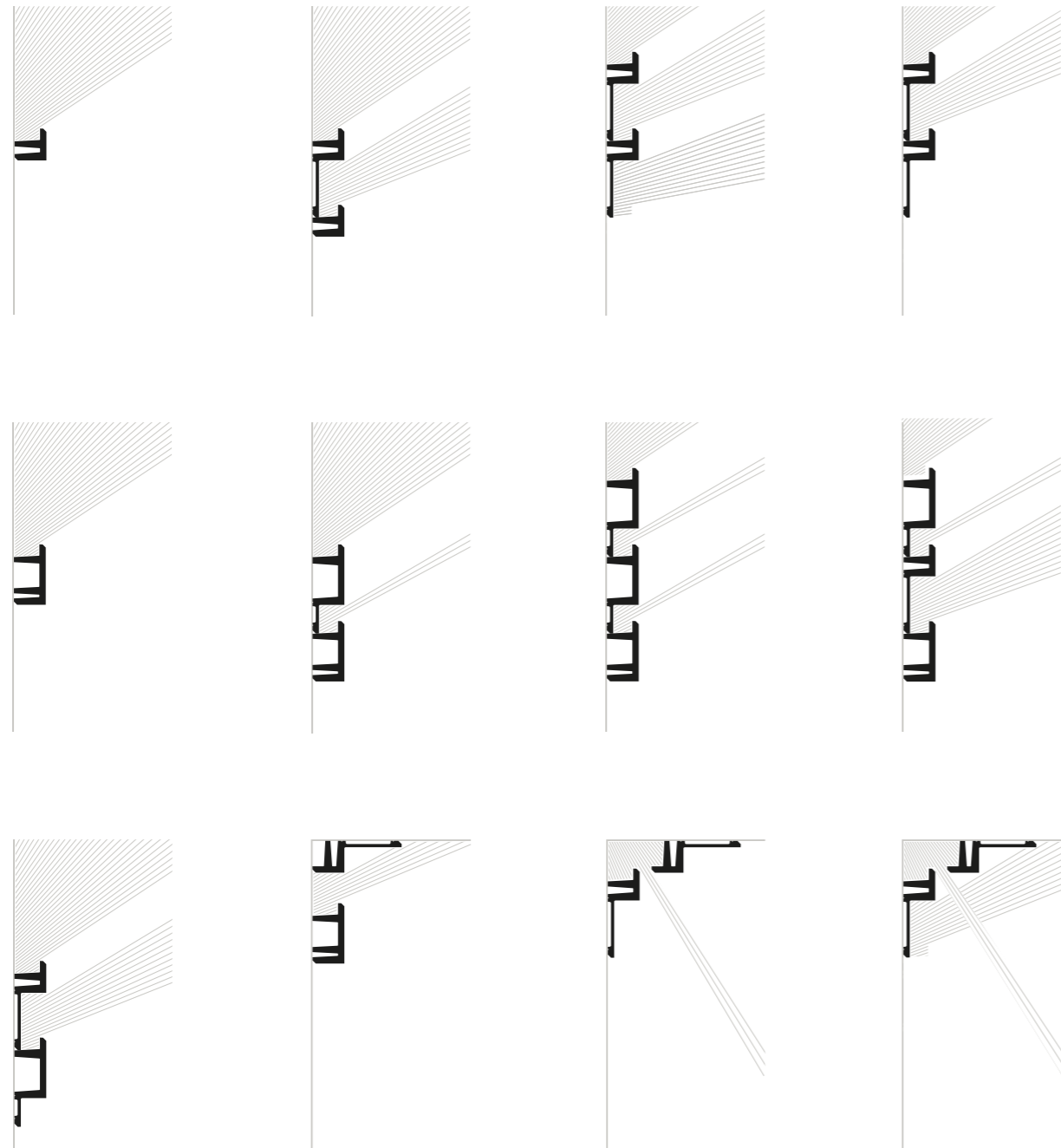

Products

1. C382 2. C383 3. C380 4. SX180 p.114

③ **C380** L3 LINEAR LED LIGHTING
Purotouch®
200 x 5 x 5 cm
Designed by Orio Tonini

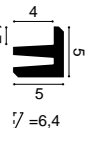

C381 L3 LINEAR LED LIGHTING
Purotouch®
200 x 9,5 x 5 cm
Designed by Orio Tonini



① **C382** L3 LINEAR LED LIGHTING
Purotouch®
200 x 14 x 5 cm
Designed by Orio Tonini

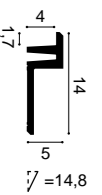

② **C383** L3 LINEAR LED LIGHTING
Purotouch®
200 x 14 x 5 cm
Designed by Orio Tonini

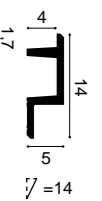

Indirect lighting



1. C394 2. C393 p.79 3. SX180 p.114

C394 C395 C396 Uplighter

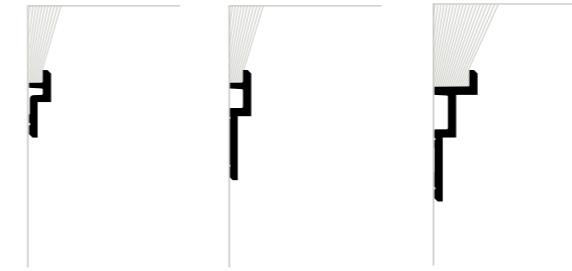

C390 C391 C394 C395 Downlighter

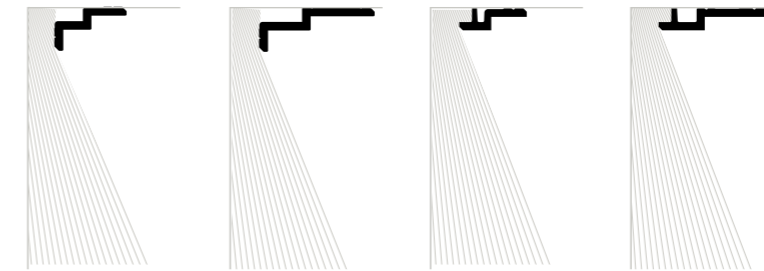

C390 STEPS
Purotouch®
200 x 6 x 10 cm
Designed by Orio Tonini

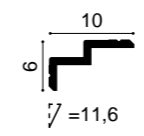

C391 STEPS
Purotouch®
200 x 6 x 16 cm
Designed by Orio Tonini

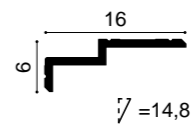

① **C394 STEPS**
Purotouch®
200 x 9,5 x 3,1 cm
Designed by Orio Tonini

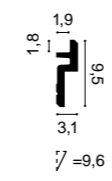

C395 STEPS
Purotouch®
200 x 15,5 x 3,1 cm
Designed by Orio Tonini

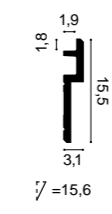

C396 STEPS
Purotouch®
200 x 18,5 x 6,1 cm
Designed by Orio Tonini

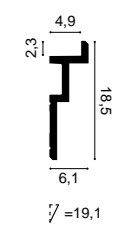

SX179 DIAGONAL
Duropolymer®
200 x 9,7 x 2,9 cm
Designed by Orio Tonini

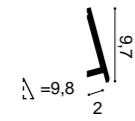

SX179 DIAGONAL
Duropolymer®
200 x 9,7 x 2,9 cm
Designed by Orio Tonini



CX197 U-STEPS
Duropolymer®
200 x 5 x 9,3 cm
Designed by Orio Tonini

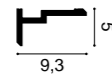

CX196 U-STEPS
Duropolymer®
200 x 11,3 x 4 cm
Designed by Orio Tonini

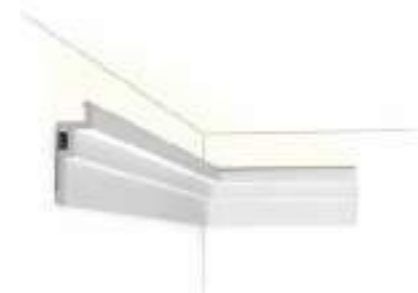
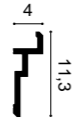

CX188 | CX188F
Duropolymer®
200 x 3,4 x 3 cm
Designed by Orio Tonini



CX189 | CX189F
Duropolymer®
200 x 2,7 x 2,7 cm
Designed by Orio Tonini



CX190 | CX190F U-PROFILE
Duropolymer®
200 x 2 x 3 cm
Designed by Orio Tonini



CX190 | CX190F U-PROFILE
Duropolymer®
200 x 2 x 3 cm
Designed by Orio Tonini



CX190 | CX190F U-PROFILE
Duropolymer®
200 x 2 x 3 cm
Designed by Orio Tonini



1. CX196 2. W115 p.102 3. CX190 p.118

Indirect lighting

C373 | C373F ANTONIO
Purotouch®
200 x 8 x 5 cm
Designed by Ulf Moritz

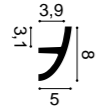

C374 ANTONIO
Purotouch®
200 x 18 x 5 cm
Designed by Ulf Moritz

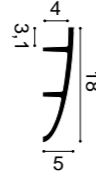

Antonio

C373 + C374



C373 + C373

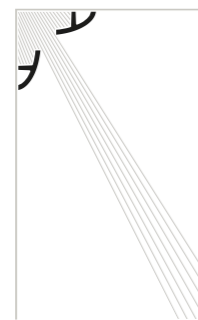

C374 + C991

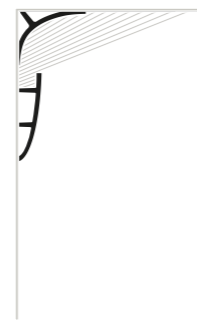

C373 + C373

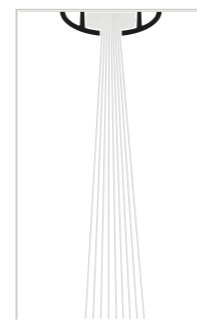

C374 + C374

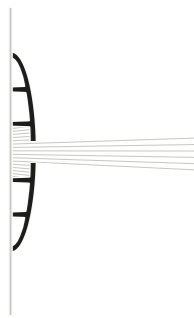

C373 + C374

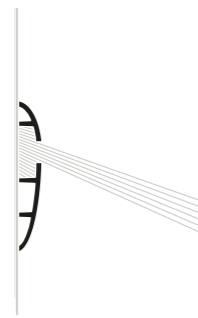

C373 + C373

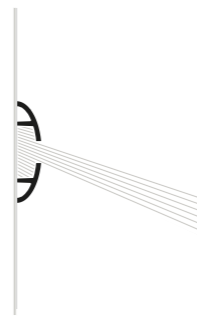

C374 + C373



C373 + C374

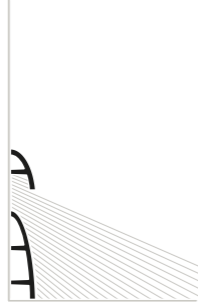

C374 + C374

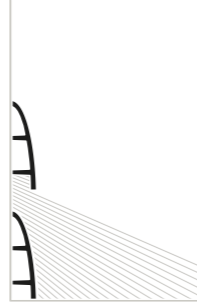

1. PX120 p.103 2. C394 p.77 3. C991 p.78 4. C361 p.129



Indirect lighting

C361 STRIPE
Purotouch®
200 x 5 x 5 cm
Designed by Pierre Daems

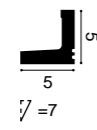

C362 CURVE
Purotouch®
200 x 5 x 5 cm
Designed by Pierre Daems

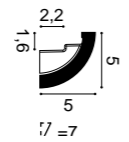

C991
Purotouch®
200 x 11 x 14 cm
Designed by Ulf Moritz

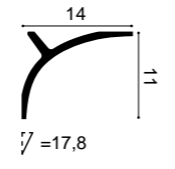

C371 SHADE
Purotouch®
200 x 18,5 x 5,8 cm
Designed by Ulf Moritz

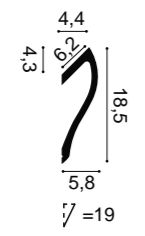

the perfect finish



PG. 158 -161

C991



Indirect lighting

Deco elements

06

ORAC

Products

ELEMENTI DECORATIVI
ELEMENTOS DECORATIVOS
أصناف للزينة
ÉLÉMENTS DÉCORATIFS

Deco elements are the subtle whispers of personality that breathe life into a space. From grandiose flourishes to understated accents, we propose options to punctuate your interior design narrative with finesse, for you to find what feels right.

IT—

Gli elementi déco sono i sottili sussurri di personalità che danno vita a uno spazio. Dai grandiosi fiori agli accenti sobri, vi proponiamo opzioni per punteggiare con finezza la vostra narrazione d'interni, affinché possiate trovare ciò che fa per voi.

PT—

Os elementos de decoração são os sussurros de personalidade que dão vida a cada espaço. De floreios grandiosos a detalhes discretos, propomos opções para pontuar o seu design de interiores com delicadeza, para que encontre o que melhor se encaixa no seu projeto.

AR—

العناصر الزخرفية هي الهمسات الشخصية الدقيقة التي تبت الحياة في المساحة. من الزخارف الفخمة الى اللمسات البسيطة، نقدم خيارات لإضفاء لمسة من البراعة على تصاميمكم الداخلية، لتمكنوا من العثور على ما يناسبكم.

FR—

Les éléments déco sont de subtils murmures de personnalité qui insufflent de la vie à un espace. Qu'il s'agisse d'ornements grandioses ou d'accents discrets, nous vous proposons des options pour ponctuer avec finesse votre récit de décoration intérieure, afin que vous trouviez ce qui vous convient.

Ceiling roses

ROSONI
ROSETAS
ورديات للسقوف
ROSACES

ORAC



¹ R64

R10 
Purotouch®
ø 15 x 4,2 - ø 2 cm



R11
Purotouch®
ø 19 x 3,6 - ø 3 cm



R12
Purotouch®
ø 19,5 x 1,8 - ø 1 cm



Products

R13 
Purotouch®
ø 28 x 3,1 - ø 2,5 cm



R14 
Purotouch®
ø 33 x 3 - ø 2,5 cm



R31 
Purotouch®
ø 38,5 x 2,7 - ø 3,5 cm



R17 
Purotouch®
ø 47 x 3,5 - ø 6,5 cm



R18
Purotouch®
ø 49 x 4,7 - ø 7 cm



R52 
Purotouch®
ø 69,5 x 4,8 - ø 12,5 cm



R73 
Purotouch®
ø 70 x 5,9 - ø 8 cm



R23
Purotouch®
ø 71 x 4,4 - ø 6 cm



R27
Purotouch®
ø 75 x 4,5 - ø 9 cm



R22
Purotouch®
77,5 x 53 x 3,6 cm



R24
Purotouch®
ø 79 x 6 - ø 8 cm



¹ R64 
Purotouch®
ø 95,2 x 4,8 - ø 7 cm



R07
Purotouch®
ø 26 x 3 - ø 5 cm

R08
Purotouch®
ø 38 x 4,2 - ø 5 cm

R09 ⊕
Purotouch®
ø 48,5 x 3,7 - ø 6 cm



R76
Purotouch®
ø 62 x 4,1 - ø 10,5 cm

① **R77**
Purotouch®
ø 62 x 4,2 - ø 10,5 cm

R40 ⊕
Purotouch®
ø 74,5 x 3,1 - ø 10 cm

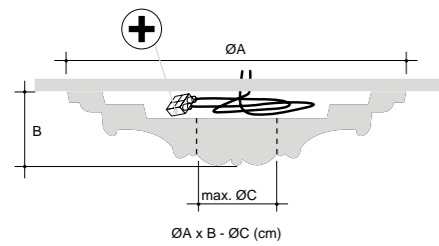

⊕ Room for cables

SPAZIO PER I CAVI
ESPAÇO PARA CABOS
مكان للكابلات
PLACE POUR LES CÂBLES



① R77

Decor elements

Door frames

CONTORNI PORTA
MOLDURAS DE PORTA
إطارات للأبواب
ENCADREMENTS DE PORTES



DX157-2300 |
DX157-2300 RAL 9003

230 x 6,6 x 1,3 cm
Duropolymer®

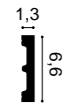

DX163-2300 |
DX163-2300 RAL 9003

230 x 10,1 x 1,3 cm
Duropolymer®

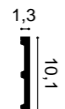

1. D170 2. D401 3. DX170-2300 4. D330LR

D210
Duropolymer®
9,6 x 9,6 x 3,5 cm

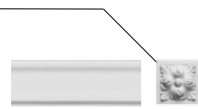

D200
Duropolymer®
9,6 x 9,6 x 3 cm

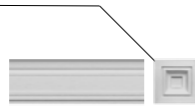

DX121-2300
Duropolymer®
230 x 9,4 x 2,3 cm

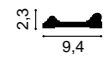

DX119-2300
Duropolymer®
230 x 9,2 x 2,2 cm

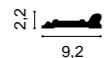

DX170-2300
Duropolymer®
230 x 11,9 x 3,2 cm

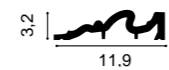

DX174-2300
Duropolymer®
230 x 6 x 2,2 cm

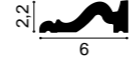

D310
Duropolymer®
9,5 x 24,9 x 3,1 cm

D310
Duropolymer®
9,5 x 24,9 x 3,1 cm

D330LR (2pc)
Duropolymer®
12,6 x 16 x 4,1 cm

D340
Duropolymer®
7 x 11 x 2,5 cm

Products

D400
Purotouch®
127,5 x 14,5 x 5,5 cm



D401
Purotouch®
127,5 x 14,5 x 5,5 cm



D402
Purotouch®
only for D400 and D401
14,5 x 12 x 5,5 cm



D170
Purotouch®
105 x 24,5 x 3,2 cm



FRONTONI
FRONTÕES
إقواس
FRONTONS

Pediments

Deco elements

PANNELI PER PORTA
PAINÉIS PARA PORTAS
تليسة الباب
PANNEAUX DE PORTES

Door panelling

D507
Duropolymer®
55 x 90,5 x 1,7 cm



D503
Duropolymer®
55 x 55 x 1,7 cm



D504
Duropolymer®
55 x 22 x 1,7 cm



Full columns

COLONNE INTERE
COLUNAS COMPLETAS
أعمدة كاملة
COLONNES ENTIÈRES

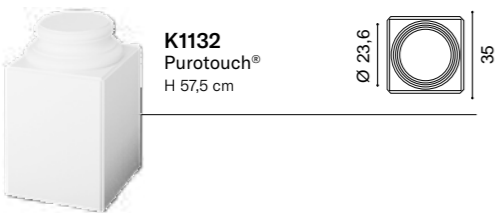
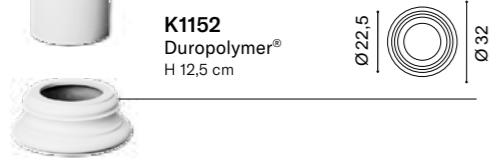
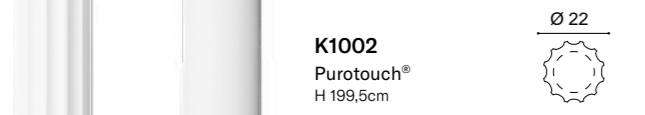

K1112 + K1002 + K1152 = 242 cm H
K1112 + K1002 + K1132 = 287 cm H max
K1122 + K1102 + K1152 = 242 cm H
K1122 + K1102 + K1132 = 287 cm H max

Half columns

MEZZE COLONNE
MEIAS COLUNAS
نصف أعمدة
DEMI-COLONNES

ORAC

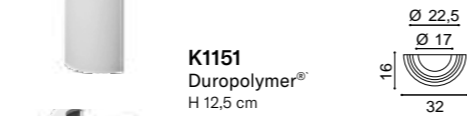
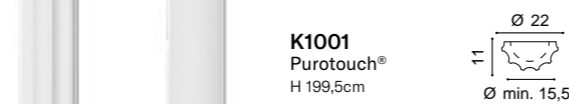
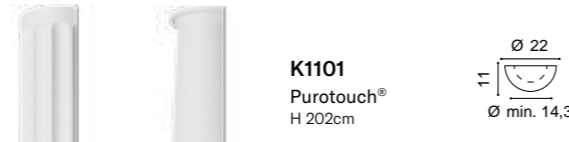

K1111 + K1001 + K1151 = 242 cm H
K1111 + K1001 + K1131 = 287 cm H max
K1121 + K1101 + K1151 = 242 cm H
K1121 + K1101 + K1131 = 287 cm H max

Products

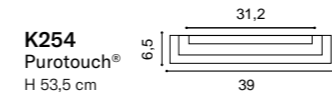
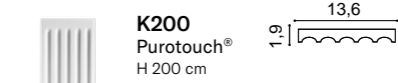
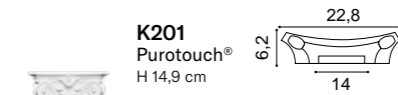
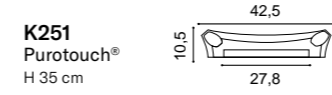

1. K1122
2. K1002
3. K1152
4. K251
5. K250
6. K254



Pilasters

PILASTRI
PILASTRAS
أعمدة مسطحة للجدران
PILASTRES

Deco elements

The perfect finish

07



LA FINITURA PERFETTA
FINISARE PERFECTA
مظهر نهائي مثالي
LA FINITION PARFAITE

We once vowed never to stop at what looks good. That's why our products stand the test of time, right down to the glue that holds them in place. Our installation products are the silent artisans behind the scenes, ensuring a seamless and straightforward installation of our architectural elements.

IT —

Una volta abbiamo giurato di non fermarci mai a ciò che sembra bello. Ecco perché i nostri prodotti resistono nel tempo, se si utilizzano i nostri materiali per la corretta posa. I nostri prodotti di installazione sono gli artigiani silenziosi dietro le quinte e garantiscono un'installazione permanente e semplice di tutti i nostri profili.

PT —

Um dia prometemos não ficar pelo que parece estar bom. É por isso que os nossos produtos resistem ao teste do tempo, até a cola que os mantém no lugar. Os nossos produtos de instalação são os artesãos silenciosos nos bastidores, garantindo uma instalação simples e sem problemas dos nossos elementos arquitetónicos.

AR —

لقد تعهدنا بعدم الإكتفاء بالمظهر الجميل. لذلك، فإن منتجاتنا تصمد أمام اختبار الزمن، بما فيها المواد اللاصقة التي تستعمل لتثبيتها. مواد التركيب لدينا هي الحرفيون الصامتون خلف الكواليس، وتضمن تركيباً سهلاً وقوياً لقوابلنا.

FR —

Nous nous sommes promis de ne jamais nous arrêter à ce qui est beau. C'est pourquoi nos produits résistent à l'épreuve du temps, jusqu'à la colle qui les maintient en place. Nos produits d'installation sont les artisans silencieux de l'arrière-scène, qui garantissent l'installation simple et sans faille de nos éléments architecturaux.

Surface and atmosphere

AMBIENTE E SUPERFICIE
AMBIENTE E SUPERFÍCIE
السطح والمحيط
ENVIRONNEMENT & SURFACE

Storage and installation conditions: Store profiles and adhesives at room temperature and wait 24 hours before installing.



Condizioni di installazione e stoccaggio:
Tenere i profili e il collante a temperatura ambiente almeno 24 ore prima della posa.



Condições de armazenamento e instalação:
guardar os perfis e as colas no local 24 horas antes da aplicação.



شروط التخزين والتثبيت: يجب وضع القوالب والمواد اللاصقة في درجة حرارة الغرفة ٢٤ ساعة قبل التركيب.

Conditions d'installation et de stockage:
Stockez les profils et les colles à température ambiante 24 heures avant la pose.



Dust free
Libero da polvere
Livre de pó
خالٍ من الغبار
Sans poussière



Sand and wash surface
Superfície pulita e liscia
Superfície lavada e areada
يجب حفر وتنظيف السطح
Ponçez et nettoyez la surface



Flat wall & ceilings
Muri e soffitti piani
Paredes e tetos lisos
جدران وسقوف مسطحة
Mur et plafond plats



Dry
Asciutto
Seco
جاف
Sec



No grease
Non unto
Sem gordura
خالٍ من الدهون
Sans graisse

Decofix adhesives

COLLANTI DECOFIX
COLAS DECOFIX
المواد اللاصقة ديكوفيكس
COLLES DECOFIX



Interior, porous and dry surface
Per interni, superfici porose, ambienti asciutti
Interior, superficies porosas e secas

سطح داخلي، مسامي وجاف
Pose à l'intérieur, surfaces poreuses, pièces non humides



Heavy profiles
Perfil pesado
ou
Perfil Pesados



Exterior, non-porous and humid surfaces and 3D Wall Covering
Per esterno, superficie non porose, ambienti umidi e rivestimento
Exterior, superficies não porosas, ambientes húmidos e revestimento de parede 3D
مسامي ورطب أو قوالب ثقيلة
Pose à l'extérieur, surfaces non poreuses, environnement humide et revêtements muraux 3D

DecoFix Pro



FDP500 310ml
> 7 — 8m

Extra strong installation adhesive for porous surfaces and interior applications

- Strong, water-based acrylic glue
- Long-lasting seal between mouldings and the wall and/or ceiling
- Remove with humid sponge or cloth
- Should be kept frost free
- Paintable after hardening (min. 24 hours)

DecoFix Power



FDP700 290ml
> 7 - 8m

Extra strong MS polymer glue for new build, all exterior applications, non-porous (tiles, glass, ...) surfaces, damp environments and 3D wall covering

- Remove with soap solution
- Paintable after hardening (min. 24 hours)

DecoFix Ultra



FX400 270ml
> 80m

White, polymer-based adhesive for joints between mouldings

- Apply sufficient DecoFix Ultra in every joint
- Push profiles strongly against each other and remove excess glue with a painter's knife before hardening.
- Use FL300 DecoFiller if needed and finish with sandpaper
- Can be painted after 24 hrs

DecoFiller



FL300 310ml
> 30m

Ready to use lightweight acrylic filler

- For shrink-proof finishing of gaps (between decorative profiles after adhesion, between wall and profiles, between walls and between wall and ceiling), cracks and irregularities in profiles or on walls
- Rapidly repaintable (after 15 min.)
- Does not crack

Colla acrilica ultra forte per superfici porose e per l'applicazione all'interno

- Colla acrilica a base d'acqua, forte
- Incollaggio a lunga durata tra le cornici ed il muro e/o il soffitto
- Rimuovere l'eccesso con una spugna o uno straccio umidi
- Tenere il prodotto al riparo dal gelo
- Può essere verniciato dopo completa asciugatura (min. 24 ore)

Colla a base di polimeri MS extra forte per costruzione nuova, l'applicazione all'esterno, superfici non porose (piastrelle, vetro, ...), ambienti umidi e rivestimento murale 3D

- Rimuovere l'eccesso con una soluzione saponata
- Può essere verniciato dopo completa asciugatura (min. 24 ore)

Adesivo bianco a base di polimero da utilizzare per saldare le giunte delle cornici

- Dopo aver applicato la colla, premere bene i profili tra di loro lungo la giunta
- La colla in eccesso deve essere rimossa prima dell'indurimento con una spatola
- Utilizzare FL300 DecoFiller se necessario e rifinire con carta vetrata
- La verniciatura può essere effettuata dopo 24 ore

Stucco acrilico leggero pronto all'uso

- Ideale come riempitivo per piccole crepe e fessure e irregolarità tra profili dopo l'incollaggio o tra parete e profili
- Indurisce senza restringere
- Rapidamente riverniciabile (dopo circa 15 minuti)
- Non si screpola

Cola Extra Forte para superficies porosas e aplicações interiores

- Cola acrilica de base aquosa
- Selagem de longa duração entre sancas e parede e/ou teto
- Fácil remoção dos resíduos da cola com uma esponja ou pano húmido
- Deve ser guardado em ambiente seco
- Pintável após endurecimento (min. 24 horas)

Extra forte, cola a base de MS polimero, para nova construção, aplicações no exterior, superficies não porosas (cerâmica, vidro, ...), ambientes húmidos e revestimento de parede 3D

- Removível com uma solução de água e sabão
- Pintável após endurecimento (min. 24 horas)

Cola à base de polimero branco para colar as pegas

- Aplique DecoFix Ultra nas superfícies a colar e aperte firmemente uma contra o outra
- Retire os restos de cola com uma espátula antes de endurecer
- Se necessário use FL300 DecoFiller e dê acabamento com lixa fina
- Podere ser pintado 24h após a aplicação

Enchimento acrílico leve pronto para usar

- Para acabamento anti-retração de fendas (entre perfis decorativos após adesão, entre paredes e tetos, paredes e perfis e na junção de paredes), fissuras e irregularidades nos perfis ou nas paredes
- Repintável rapidamente (após 15 min.)
- Não fissura

لاصق قوي جدا لتركيب القوالب على أسطح مسامية وفي الداخل

- لاصق قوي جدا لتركيب القوالب على أسطح مسامية وفي الداخل
- لاصق متين بين القوالب والجدار وأو السقف
- يزال بالبلل، والصابون
- يمكن طلاؤه بعد أن يصلب (24 ساعة على الأقل)

لاصق بوليمري أبيض للصلق القوالب ببعضها

- لاصق بوليمري أبيض للصلق القوالب ببعضها
- تعد كمية كافية من ديكوفيكس التزا في كل فاصل
- تضغط القوالب بقوة على بعضها ويزال الفائض اللاصق بواسطة منشفة صغيرة قبل أن يصلب
- يمكن استخدام FL300 ديكوفيلر إن لزم الأمر والتنعيم بورق زجاج
- يمكن طلاؤه بعد ٢٤ ساعة

معجونة أكريليك خفيفة الوزن جاهزة للإستخدام

- معجونة أكريليك خفيفة الوزن جاهزة للإستخدام
- ملء الفجوات، الشقوق وغيرها من العيوب في القوالب أو الجدران (بين القوالب بعد لقصها، بين القوالب والجدار، بين الجدران وبين الجدار والسقف)
- قابلية الطلاء بسرعة (بعد 15 دقيقة)
- غير قابلة للإتكماش أو التشفق

Colle d'installation ultra forte pour surfaces poreuses et applications intérieures

- Colle forte à base d'eau et d'acrylique
- Joint longue durée entre les moulures et le mur et/ou le plafond
- Retirez à l'aide d'une éponge ou d'un chiffon humide
- Doit être conservé à l'abri du gel
- Peut être peint après séchage (min. 24h)

Colle au MS polymère extra forte pour constructions nouvelles, utilisation extérieure, surfaces non poreuses (carrelage, verre, etc...), environnements humides et revêtements muraux 3D

- Enlevez à l'aide d'une solution savonneuse
- Peut être peint après séchage (min. 24h)

Colle blanche à base de polymères pour les joints entre profils

- Appliquez une quantité suffisante de DecoFix Ultra pour chaque joint sur le côté du profil déjà installé.
- Pressez les deux profils fortement l'un contre l'autre.
- Éliminez les excès de colle en utilisant un couteau peinture avant le durcissement.
- Utiliser du FL300 DecoFiller si nécessaire et finir avec du papier de verre.
- Peut être peint après 24 hrs.

Enduit léger prêt à l'emploi à base d'acrylique

- Pour une finition irrétractible de joints (entre profils décoratifs après adhésion, entre murs et profils, entre mur et plafond et murs entre eux), fissures, trous et irrégularités dans les profils ou les murs
- Peut être recouvert rapidement (après 15 min.)
- Ne se fissure pas

Tools

ACCESSORI
ACESSÓRIOS
لوالم
ACCESSOIRES



FB15

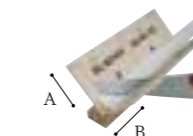

FB300
A: 29,7 cm | B: 29,1cm

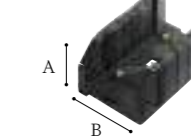

FB13
A: 12,5 cm | B: 15,5 cm



A38

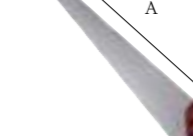

FB14
A: 60 cm



FB10
A: 27,5 cm | B: 22 cm

Installation videos & manuals

VISIT WWW.ORACDECOR.COM/INSTALLATION OR SCAN THE QR CODE



Flexible products

ORAC

08

Products

PROFILI FLESSIBILI
PRODUTOS FLEXÍVEIS
المنتجات المرنة
PRODUITS FLEXIBLES

You may expect walls to be straight by nature. But we invite you to imagine a flowing interior. Many of our solutions are flexible, following or effectively suggesting a curve in a wall. As far as we're concerned, a rounded corner should never be out of the question.

IT —

Ci si aspetta che le pareti siano dritte per natura. Ma vi invitiamo a immaginare un interno fluido. Molte delle nostre soluzioni sono flessibili e seguono o delineano efficacemente la curva di una parete. Perché per noi un angolo arrotondato non dovrebbe mai essere tralasciato.

PT —

É de esperar que as paredes sejam direitas por natureza. Mas deixamos o desafio para que imagine um interior fluido. Muitas das nossas soluções são flexíveis, seguindo ou sugerindo uma curva numa parede. Porque, para nós, um canto arredondado nunca deve estar fora de questão.

AR —

قد تكون الجدران مستقيمة بطبيعتها. لكننا ندعوكم إلى تخيل تصميم داخلي انسيابي، تتميز العديد من أصنافنا بالمرونة، وتتبع بشكل دقيق منحنى في الجدار. لأنه بالنسبة لنا، إن زاوية مستديرة لا يجب أبدًا أن تكون أمرًا غير وارد.

FR —

On peut s'attendre à ce que les murs soient droits par nature. Mais nous vous invitons à imaginer un intérieur fluide. Nombre de nos solutions sont flexibles, suivant ou suggérant efficacement la courbe d'un mur. Car pour nous, un coin arrondi ne devrait jamais être exclu.

Flex Radius	R min in cm	R* min in cm	R**min in cm	Flex Radius	R min in cm	R* min in cm	R**min in cm	Flex Radius	R min in cm	R* min in cm	R**min in cm
C211F	250			CX199F	200			SX165F	40		
C213F	280			DX174F	60	300		SX172F	35		
C215F	160			P3020F	50	180		SX173F	45		
C217F	380			P4020F	40	200		SX180F	45		
C220F	400			P4025F	70			SX182F	35	100	
C230F	150			P5021F	20	70		SX183F	40		
C240F	270			P7070F	30	230		SX184F	45		
C250F	70			P8020F	40	130		SX187F	40		
C304F	250			P8030F	20	70		SX194F	25	80	
C321F	140			P8040F	30			SX195F	30		
C325F	300			P8050F	80	200		W108F	30		40
C326F	500			P9010F	40	310		W109F	30		40
C331F	420			P9050F	20	60		W110F	30		40
C333F	300			P9900F	20	250		W111F	30		40
C334F	380			PX103F	20	80		W114F	30		40
C339F	380			PX120F	30	110		W116F	30		40
C341F	400			PX144F	20	220		W119F	30		40
C373F	100			PX175F	30	80		W214F	30		40
C901F	600			PX198F	70			WX205F	30		40
C902F	600			PX201F	30	80		WX210F	30		40
CX100F	200			PX202F	60	150		WX211F	30		40
CX106F	360			PX209F	20	70		SX207F	40		
CX109F	160			SX104F	40						
CX110F	180			SX105F	30						
CX123F	280			SX118F	40						
CX124F	160			SX137F	40						
CX127F	240			SX138F	40						
CX132F	70			SX155F	30						
CX188F	110			SX157F	35	260					
CX189F	90			SX162F	20	80					
CX190F	30	130		SX163F	35						

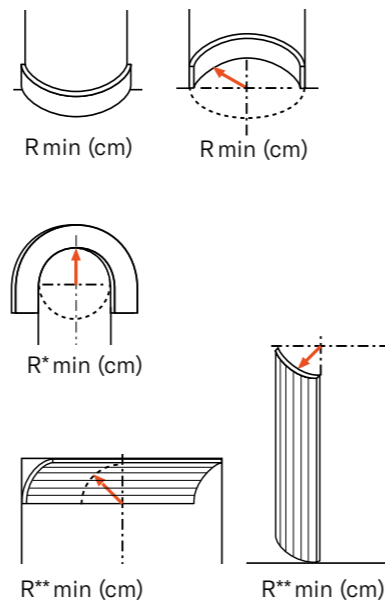

1. W108F p.164

Index

C

C200	69
C201	73
C211 C211F	40, 41, 42, 50, 51, 70, 71
C212	73
C213 C213F	69, 70
C215 C215F	69
C216	69
C217 C217F	69
C219	73
C220 C220F	69
C230 C230F	69
C240 C240F	76
C250 C250F	76
C260	76
C301	69
C303	73
C304	73
C305	40, 41, 42, 50, 51, 70, 71
C305 + C211	40, 41, 42, 50, 51, 70, 71
C305 + C213	70
C307	70
C307 + C307A	70
C307A	40, 41, 42, 50, 51, 70, 71
C321 C321F	74
C322	69
C323	136
C324	136
C325	67
C326	67
C327	67
C331	73
C332	34, 35, 36, 37, 74, 75
C333 C333F	73
C334 C334F	73
C336	68
C338	68
C338A	68
C338B	68
C339 C339F	74
C340	74, 83
C341 C341F	66, 83
C342	66, 83
C343	46, 47, 52, 53, 66, 83, 117
C344	66
C352	137
C353	80
C354	80
C355	80, 81
C356	80
C357	137
C360	80
C361	145, 146
C362	146
C371	146
C373 C373F	144
C374	144
C380	139
C381	139

C382	139
C383	139
C390	27, 79, 83, 141
C391	25, 26, 30, 79, 83, 141
C392	27, 79
C393	25, 26, 30, 79
C394	30, 79, 83, 141, 145
C395	79, 83, 141
C396	79, 83, 141
C400	80
C422	70
C602	80
C900	73, 137
C901 C901F	73, 137
C902 C902F	73, 137
C990	14, 15, 76, 77
C990 + 2x P9900	77
C990 + P9900	77
C991	77, 81, 83, 145, 146
C991 + 2x P9900	31, 77
C991 + P9900	77
CB500N	90
CB501N	90
CB502N	90
CB503N	91
CB510N	90
CB511N	90
CB512N	90, 91
CB520N	90
CB521N	90
CB522N	90
CB523N	90
CB524N	91
CB525N	90
CX100 CX100F	84
CX106 CX106F	84
CX107	85
CX108	85
CX109 CX109F	86
CX110 CX110F	84
CX111	85
CX112	85
CX115	86
CX123 CX123F	84
CX124 CX124F	84
CX126	86
CX127 CX127F	84
CX129	85
CX132	86
CX133	86
CX134	131
CX141	86
CX148	86
CX160	54, 89
CX161	89
CX176	86
CX177	85
CX188 CX188F	14, 15, 30, 31, 76, 142
CX189 CX189F	142
CX190 CX190F	18, 19, 25, 26, 28, 29, 87, 101, 102, 116, 118, 120, 130, 142, 143

CX192	86
CX196	83, 87, 102, 142
CX197	83, 87, 130, 142
CX199 CX199F	84
CX203	84

D

D170	154
D200	154
D210	154
D310	154
D330LR	41, 52, 105, 154
D340	154
D400	155
D401	155
D402	155
D503	155
D504	155
D507	155
DX119-2300	128, 155
DX121-2300	128, 155
DX157-2300	155
DX163-2300	155
DX170-2300	41, 52, 105, 112, 128, 154, 155
DX174-2300 DX174F	128, 155

F

F30	107
------------	-----

K

K200	157
K201	157
K202	157
K250	157
K251	157
K254	157
K1001	156
K1002	156
K1101	156
K1102	156
K1111	156
K1112	156
K1121	156
K1122	156
K1131	156
K1132	156
K1151	156
K1156	156

P

P20	133
P101A	133
P801C	133
P1020	125
P3020A	39, 132, 133
P3020 P3020F	125
P3070	126
P3071	126
P4020A	133
P4020 P4020F	40, 41, 42, 46, 52, 124, 128
P4025 P4025F	124
P5021 P5021F	126
P6020	125
P7020	125
P7030	125
P7070 P7070F	27, 114, 119, 126
P8020 P8020F	46, 52, 66, 67, 75, 84, 117, 124, 125, 128

P8030C	133
P8030D 133	
P8030 P8030F	38, 39, 51, 54, 67, 71, 84, 88, 124, 125

P8040 P8040F	124
P8050 P8050F	39, 50, 124, 125, 132
P8060	126
P9010 P9010F	48, 49, 112, 124, 127
P9020	124
P9040	124
P9050 P9050F	48, 49, 112, 126, 127
P9900 P9900F	24, 31, 77, 126
P9901	126
PX103 PX103F	91, 110, 129
PX103A	133
PX113	129
PX116	129
PX117	129
PX120 PX120F	129
PX120A	133
PX144 PX144F	129
PX147	130
PX169	130
PX175 PX175F	129
PX198 PX198F	87, 102, 116, 118, 130
PX201 PX201F	129
PX202 PX202F	129
PX209 PX209F	14, 15, 36, 97, 98, 99, 130, 131, 136

R

R07	152
R08	152
R09	152
R10	150

R11	150
R12	150
R13	151
R14	151
R17	151
R18	151
R22	151
R23	151
R24	151
R27	151
R31	151
R40	152
R52	151
R64	151
R73	151
R76	152
R77	152

S

SX104 SX104F	115
SX105 SX105F	112
SX118 SX118F	93
SX125	116
SX137 SX137F	113
SX138 SX138F	34, 36, 37, 105, 113
SX155 SX155F	48, 112
SX156	115
SX157 SX157F	89, 111, 118, 131
SX159	126
SX162 SX162F	89, 111, 118, 131
SX163 SX163F	89, 111, 118, 131
SX165 SX165F	111
SX168	118, 131
SX171	111, 121
SX172 SX172F	116
SX173 SX173F	111
SX179	116, 142
SX180 SX180F	25, 27, 30, 114, 119, 139, 140
SX181	114, 119
SX182 SX182F	14, 17, 89, 99, 111, 119, 131
SX183 SX183F	89, 111, 119, 131
SX184 SX184F	89, 111, 119, 131
SX185	111, 121
SX186	111, 121
SX187 SX187F	114, 119
SX191	51, 52, 53, 67, 71, 115
SX193	113
SX194 SX194F	19, 24, 89, 116, 118, 131
SX195 SX195F	112
SX206	46, 113, 128
SX207 SX207F	26, 95, 118, 130, 131
SX212 <small>NEW</small>	119, 131

W

W100	106
W101	106
W105	106
W106	106
W107	106
W108 W108F	96, 165
W109 W109F	48, 49, 98, 117, 136
W110 W110F	20, 21, 36, 96, 97
W111 W111F	25, 87, 101
W112	103
W113	103
W114 W114F	18, 19, 98
W116 W116F	25, 87, 121
W115	16, 102, 143
W119 W119F	25, 87, 121
W120	104, 105, 113, 115
W121	104, 105, 113, 115
W122	104, 105
W123	104, 105
W130	103
W212	98, 136
W213 <small>NEW</small>	96, 97
W214 W214F <small>NEW</small>	34, 35, 36, 37, 96, 97
W215 <small>NEW</small>	34, 35, 36, 37, 96, 97
W216 <small>NEW</small>	26, 102, 103
W217 <small>NEW</small>	14, 17, 99
W218 <small>NEW</small>	14, 17, 99
WX204	95
WX204-2600	95
WX205 WX205F	95
WX205-2600	95
WX210 WX210F <small>NEW</small>	36, 95, 97
WX210-2600	36, 95, 97
WX211 WX211F <small>NEW</small>	36, 95, 97
WX211-2600	36, 95, 97

Colofon

Concept

Base Design
zwerms.studio

Graphic design

zwerms.studio

Special thanks to

BLCN Design	blcn-design.com	8
The HUB Ghent	thehub.be	18–19
Maison Numéro 20	maisonnumero20.fr	20–21
Atelier DAAA	atelierdaaa.com	28–29, 88, 120
Marie-Emilie Geerinckx	marieemiliegeerinckx.be	30–31, 140
Aboco	aboco.be	38–39, 132
Geoffroy Van Hulle	geoffroyvanhulle.com	40–41, 42–43, 54–55, 76, 84
Van Damme - Vandeputte architects	vandammevandeputte.com	50–51, 71, 122, 125
LOFT4C	loft4c.be	52–53
Anthony Boelaert	anthonyboelaert.be	68
Interieurprojects	interieurprojects.com	81
Sur Mesure Interieur	surmesure-interieur.be	75, 82
Sofie de Kruijff	thehomestyleclub.com	98
Atelier En Aparté	atelierenaparté.com	106
Blume Studio	blumestudio.es	107
Madrid Forest	madridforest.com	107
Hotel Du Parc Oostende	hotelduparc.be	110
D-ZAJN	d-zajn.be	110
Hotel Astoria De Haan	hotelastoria.be	115
Roelfien Vos	roelfienvos.com	145, 147
Perfect Living	perfectliving.be	150
Alina Vilhjálmsdóttir		153
Eichholtz	eichholtz.com	157
Belén Imaz	belenimaz.com	107
Cafeine	cafeine.be	18–19, 28–29, 50–51, 71, 88, 115, 120, 122, 125
Damon De Backer	damondebacker.com	43
Didier Delmas	didierdelmas.com	20–21
DVO Photographic	dvo-photographic.be	81
Hannelore Veelaert	hanneloreveelaert.com	8, 38–39, 110, 132
Lotte van Uittert	lottevanuittert.com	98
Rebecka Oftedal		106
Stephanie Mathias	stephaniemathias.be	75, 82
Tijs Verweken	tijserverveken.com	30–31, 40–41, 42–43, 52–53, 54–55, 76, 84, 140
Verne	verne.be	
Willem Van Puyenbroeck	willemvanpuyenbroeck.com	150

ORAC Headquarters | nv Orac sa

Biekorfstraat 32
8400 Ostend, Belgium
T +32 59 80 32 52
info@oracdecor.com

ORAC Benelux

Biekorfstraat 32
8400 Ostend, Belgium
NL: T +31 852 08 40 59
BeLux: T +32 59 79 02 82
benelux@oracdecor.com

ORAC Deutschland

Boltensternstraße 159A
50735 Köln, Deutschland
T +49 221 747 499 39
deutschland@oracdecor.com

ORAC Österreich

T +43 662 23 49 27
oesterreich@oracdecor.com

ORAC France

13 Rue Séguier
75006 Paris, France
T +33 188803631
france@oracdecor.com

ORAC Export

T +32 59 79 02 83
export.cs@oracdecor.com

ORAC Slovakia s.r.o.

Kpt. Nalepku 6
08271 Lipany, Slovakia
T +421 232 784 952
slovakia@oracdecor.com

ORAC España

C/ del Rosselló, 229
08008 Barcelona, España
T +34 938 56 49 00
spain@oracdecor.com

ORAC (UK) Ltd.

216 Afon Building, Worthing Road
Horsham, RH12 1TL UK
T +44 1403 240 102
uk@oracdecor.com

Orac Ireland

T +35 381 8000 280
ireland@oracdecor.com

ORAC Italia srl

Corso Giacomo Matteotti, 5/H
23900 Lecco (LC), Italia
T +39 0341 362062
italia@oracdecor.com

ORAC Polska

ul. Pomorska 106A
91-402 Łódź, Polska
T +48 42 203 60 56
polska@oracdecor.com

ORAC Schweiz

T 0800 562 118
switzerland@oracdecor.com

Guarantee terms and conditions apply if provided installation instructions have been followed to the letter. Fire retardant standards. In many interiors and projects strict fire regulations are imposed. Therefore, ORAC has implemented a number of solutions depending on the country and its regulations. Please contact us for more information. The information in this catalogue is without engagement. Changes and discrepancies in sizes or/and shapes against those stated in the catalogue can occur. This catalogue and the design embodied within are protected by copyright law and international treaties. Unauthorized reproduction of the catalogue, any portion of it or the reproduction of the designs embodied therein may result in severe civil and criminal penalties and will be prosecuted to the maximum.

Further legal information can be found on: www.oracdecor.com/nl/disclaimer.



This catalogue is printed on FSC-certified paper.

ORAC PRA C

WWW.ORACDECOR.COM

